

THE BOOK
OF THE
OLD EDINBURGH
CLUB

The Journal for
Edinburgh History



This article is extracted from **The Book of the Old Edinburgh Club, The Journal for Edinburgh History** ISSN 2634-2618

Content © The Old Edinburgh Club and contributors. All rights reserved.

For further information about the BOEC, including contents of previous issues and indexes, see <https://oldedinburghclub.org.uk/boec>.

This article is made available for your personal research and private study only.

For any further uses of BOEC material please contact the Editor, The Book of the Old Edinburgh Club, at editor@oldedinburghclub.org.uk.

Digitised by the Centre for Research Collections, Edinburgh University Library from the copy in the Library Collection.



AN EDINBURGH INTRIGUE: BREWSTER'S SOCIETY OF ARTS AND THE PANTOGRAPH DISPUTE

A D C SIMPSON

THIS ARTICLE IS CONCERNED with an extended dispute that took place in Edinburgh in the years between 1820 and 1830. Although the dispute is about the plagiarism of inventions, its interest lies in its essential Edinburgh context and in the establishment values it illuminates. To a large extent it centred on what was to become an important Edinburgh institution, the embryo 'Society for the Encouragement of the Useful Arts in Scotland', normally abbreviated as the 'Society of Arts'. This prestigious and influential improving society for the promotion of invention was launched in 1821 by the redoubtable polymath David Brewster, and it continues to the present day as the Royal Scottish Society of Arts.

The particular inventions at issue were closely related and deceptively simple mechanical devices for making copies of plans and drawings. They form part of a class of machines which can be described as pantographs. Initial enquiries about some of these devices were carried out in 1967 by D. J. Bryden, my predecessor at the Royal Scottish Museum. But it was not until much later that private correspondence to Brewster was discovered in the Archives of the Royal Scottish Society of Arts (now held by the National Library of Scotland), and the nature of the affair and the extent to which it had been suppressed by Brewster could be appreciated.¹ The Museum has been able to acquire examples of the other pantographs that were involved in the dispute, and the course of the affair can now be charted with greater confidence.

EDINBURGH IN 1820

The Edinburgh of 1820 was an urbane capital city, respected as one of the great centres of learning of

western Europe. It was also the administrative centre of Scotland – the home of the courts and the various Government boards through which the country was managed, the centre of the web of political patronage that formed Scotland's power-base, and the focus of the financial and legal affairs of the landed classes. In addition, it exhibited all the activity associated with a thriving commercial merchant city of considerable size.

Twenty years earlier, Edinburgh had been, by a substantial margin, the largest city in mainland Britain after London. Only in about 1820, with its population at 140,000, was it being overtaken in size by the extraordinary growth of the new centres of industrialised manufacture. Edinburgh's pattern of growth was very different. The old city had burst its bounds in the 1780s, and in the succeeding years the great Georgian expanse of the New Town was built to the north by architects and speculative builders catering for the needs of the gentry, but also to a large extent for the aspirations and increasing success of the prosperous merchant and professional classes.²

A feeling of confident growth was apparent in many of Edinburgh's institutions. In particular, the vast undertaking of Robert Adam's new buildings for the University was proceeding apace in 1820, in the capable hands of the architect William Playfair.³ Without doubt one of Edinburgh's most extravagantly ambitious public buildings, it was begun in 1789 but had ground to an ignominious halt some years later, only partly constructed. Deft political footwork had secured substantial Government funds after the Napoleonic Wars. In 1820 it seemed clear that the project would soon be brought to a fitting conclusion;

the city's University would soon be housed in a manner appropriate to its international reputation.

The University belonged to the city in a real as well as a symbolic sense. The youngest of the four ancient Scottish universities, it was the only one founded after the Reformation. The Town Council acted as its Patron, managing its affairs in a so-called 'College Committee', and from the mid-eighteenth century the Council took an active interest in University affairs. George Drummond, an astute political manager who was to all intents and purposes perpetual Lord Provost for much of the eighteenth century, arranged University appointments to secure the teachers most able to develop the University's potential to help regenerate Edinburgh's (and Scotland's) depressed economy after the Union of the Parliaments in 1707.⁴ Drummond's influence is seen in the appointment of great eighteenth-century figures such as Colin Maclaurin, Alexander Monro *primus*, William Cullen, Adam Ferguson and William Robertson.⁵ All of these played a significant part in raising the University's profile, not only attracting Scots who would otherwise have studied abroad but also growing numbers of English non-conformists and colonials. His commitment to the medical school in particular is seen in his vigorous work to establish the city's Royal Infirmary, the great teaching hospital which was completed in 1748. Edinburgh's remarkable cultural flowering in the second half of the eighteenth century centred largely on this and the subsequent generation of academic appointments, mainly in scientific and medical disciplines. And although the Enlightenment period is marked for its range of achievement, the common purpose that directs this progress is the philosophy of scientific enquiry.

The success of the University and its medical school continued to rise until the 1820s, when it probably reached its zenith.⁶ Experienced students and graduates were being exported in huge numbers, equipped with the best scientific education then

available in Britain. Some of the classes had grown to substantial sizes: Thomas Charles Hope, Professor of Chemistry, was lecturing to classes of well over 500 in the mid 1820s.⁷

But instruction was not solely the province of the University professors. Many private lecturers also gave extra-mural courses, sometimes to supplement University courses, and sometimes in association with the Royal Colleges of Surgeons and Physicians of Edinburgh, in preparation for taking their licence examinations. These lecturers were numerous enough to be included in a guide book for students issued in 1822.⁸ The most charismatic was probably the anatomist Robert Knox, implicated in the Burke and Hare case in 1829, whose classes were almost as large as Hope's.⁹

SCIENTIFIC ENQUIRY AND EDINBURGH SOCIETY

It would be a mistake to think that these university and extra-mural lecture classes were always dry undergraduate affairs; they were often impressive (and sometimes virtuoso) performances, attended regularly by the Edinburgh establishment. At a time when a University professor's salary often depended directly on the number of individual class fees paid, there was a strong argument for playing to the gallery, even to the extent of arranging special classes. Knox gave courses in anatomy for lawyers, and Hope's chemistry demonstrations for ladies were part of the Edinburgh social scene. John Leslie, Professor of Natural Philosophy, went to extreme lengths in his attempts to emulate Hope's lecturing success, even dyeing his hair startling colours to attract attention.¹⁰

In addition, however, many professors were prepared to encourage promising individuals of humbler origins and would permit them to attend regular courses, in some instances probably waiving fees. Thus, in the 1790s, a self-taught mathematician who worked in an Edinburgh publishing house: William Wallace, attracted the attention of John

Robison, Leslie's predecessor as Professor of Natural Philosophy, and the great John Playfair, then Professor of Mathematics, and was invited to attend their classes.¹¹ Later, with Playfair's patronage, he advanced rapidly; ultimately he secured Playfair's chair at his death in 1819, and played a central role in the pantograph dispute.

Two other players in the intrigue were also able to benefit in this way. The civil engineer Robert Stevenson (grandfather of Robert Louis Stevenson) was 30 and already a partner in his step-father's firm when he attended chemistry and mathematics classes at the University to equip him more adequately for the technical work in lighthouse design that lay ahead of him.¹² Alexander Adie, almost exactly Stevenson's contemporary, was a talented scientific instrument-maker whose uncle and partner John Miller worked very closely with Robison and Leslie. Adie also attended lectures, perhaps at about the same time, although these were at his own expense.¹³ The scientific reputations of both men were such that they came to be elected Fellows of the Royal Society of Edinburgh.

But these examples are not exceptional: indeed it is clear that some form of university-level scientific education was enjoyed by many of the mobile professional groups and that an active interest in science was widespread in Edinburgh society. The vehicles for scientific interaction were threefold. In addition to lecture courses, there were specialist societies and scientific periodicals, and both of these Edinburgh had in profusion.

The most august of these societies was the Royal Society of Edinburgh.¹⁴ In 1820 the eminent geologist Sir James Hall of Dunglass retired as President and was succeeded by Sir Walter Scott, who was to play the co-ordinating role in George IV's triumphant visit to Edinburgh in 1822. The Secretary of the Royal Society at the period was David (later Sir David) Brewster, a highly-respected experimental scientist

with an international reputation, to whom we will return shortly. Around the Royal Society there were many other scientific societies, the majority with serious aims, and with interests in areas such as astronomy, medicine, natural history, natural philosophy, agricultural improvement and even phrenology.¹⁵ One that figures in the episode described below was the influential Wernerian Natural History Society (named after the German Neptunian geologist A. G. Werner), whose President was Robert Jameson, Regius Professor of Natural History at the University. The Wernerian Society, in common with a number of others, published scientific transactions.

At this period Edinburgh publishers, including the principal houses of Constable and Blackwood, are remembered mainly for their vigorous literary and review journals, many of which had a significant scientific component. But the Edinburgh presses also maintained a substantial output of scientific works of all sorts, including serials and part-issued reference works. Half a dozen scientific journals emanated from Edinburgh in the 1820s, as did the rapidly expanding *Encyclopaedia Britannica*, and its rival the Brewster-edited *Edinburgh Encyclopaedia*. Preparing the engraved plates of these books and serials was a minor industry in itself, and Edinburgh engravers and cartographers soon acquired a wide reputation. Robert Kirkwood was one Edinburgh engraver who was known to be well respected in London, and it should be remembered that it was W. H. Lizars of Edinburgh that John James Audubon commissioned to engrave the first plates of his great *Birds of America*.¹⁶

BREWSTER AND THE KALEIDOSCOPE

David Brewster (fig. 1), was the son of the village schoolmaster at Jedburgh: he had shown a precocious aptitude for science, and when he was sent to Edinburgh University to study divinity he was soon attracting attention in the science classrooms. Normally the recognition of such great ability as Brewster displayed would lead to a suitable



Fig. 1. David Brewster (1781-1868), Secretary of the Royal Society of Edinburgh and Director of the Society of Arts for Scotland. Chalk drawing by William Bewick, 1824. (*Scottish National Portrait Gallery; PG 1044.*)

preferment: however, it was not material comfort but financial insecurity that marked much of Brewster's early life.¹⁷ He was unable to take up a position in the Church, a career that could have supported him in his scientific work, because he frequently found himself paralysed with nerves when attempting to speak in

public. This also effectively barred him from a Scottish university chair, although he became sufficiently desperate to make heroic efforts to obtain the Edinburgh Natural Philosophy chair in 1833 after Leslie's death (and eventually became Principal first of St Andrews and then of Edinburgh Universities).

Instead, he turned to his pen and made his early livelihood as an editor and a prolific scientific journalist. In 1820 he was editing jointly with Jameson an exciting new venture, the quarterly *Edinburgh Philosophical Journal*, but he was also contributing scientific reviews regularly to a wide range of literary, scientific and evangelical journals. His major project was the vastly ambitious *Edinburgh Encyclopaedia*, begun for Blackwood in 1807, which hung like a millstone round his neck until it was completed in 1830.¹⁸ At the same time he was reduced to contributing major articles to the 4th, 5th and 6th editions of the rival *Britannica* for the money they brought in.¹⁹

Brewster made his scientific reputation for his experimental work in optics. His published output in this field was prodigious, with many hundreds of papers to his name. His concern was with what could be determined about the fine structure of materials from their optical characteristics, and so he was particularly drawn to investigate the complex polarisation effects found in many crystal structures.

One practical issue with which Brewster wrestled was the design of accurately corrected lenses that could be used for high-resolution microscopes. This was a serious problem that had defeated earlier workers and would not be resolved until the 1830s: Brewster proposed a novel alternative approach which was at least partly successful.²⁰ He had made exhaustive determinations of the dispersive powers of some 200 optical materials, published in 1813 in his first book, *A Treatise on New Philosophical Instruments ... with Experiments on Light and Colour*. In this he proposed the use of exotic crystalline materials with high refractive indices but low dispersive powers in order to construct high-performance lenses. In the following years he worked closely with the optical worker Alexander Adie, who was able to construct for him minute and very powerful lenses ground from garnet and sapphires.

Brewster's 1813 *Treatise* illustrates clearly his concerns for precision instruments and his understanding of the natural philosopher's obligations to use his grasp of science to develop devices of more general utility and value. One of the instruments described in the *Treatise* was the subject of Brewster's first patent, a telescope with an internal micrometer, which he had patented jointly with the London instrument maker William Harris in 1811.²¹

His next venture into patenting was a bruising experience, the memory of which remained with him for the rest of his life. The idea for the kaleidoscope, that delightful optical toy which has enchanted millions, came to Brewster in about 1815, and in 1817 he applied for and obtained patent protection.²² However, the patenting process was not only antiquated, cumbersome and expensive, it was also long drawn out and carried a serious risk of the invention being pirated before the formalities were complete. In the case of the kaleidoscope, Brewster entrusted it to a London instrument maker (Alison Morrison-Low has tentatively identified him as the same William Harris) who made the mistake of disclosing it prematurely to other manufacturers who were quick to recognise its sales potential.²³

Brewster had devised two versions of the kaleidoscope. The 'polyangular' form was made under licence by Robert Brettell Bate of London, as an opulent device of which perhaps only 60 were produced. The more versatile 'telescopic' form was manufactured in much greater numbers and several instrument makers and retail agents were authorised by Brewster to handle it. Unfortunately he could not get it manufactured fast enough, and pirated instruments flooded the market. The kaleidoscope did bring him valuable profits, but when it is appreciated that an estimated 200,000 'unofficial' instruments sold in London and Paris in the first three months alone, it is clear that a sizeable fortune had slipped through his fingers.²⁴

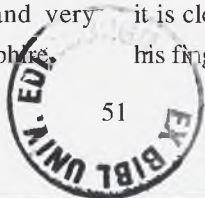

THE SOCIETY OF ARTS

Brewster's misfortune over the kaleidoscope patent, and his almost perpetual financial problems, made him a tireless campaigner for patent law reform. He argued strongly for Government support to improve the status of scientists and inventors in Britain. One lasting result of his programme of pressure was his instigation of the British Association for the Advancement of Science in 1831.²⁵ In 1820, however, he was turning his mind to devising a patronage structure which would offer Scottish inventors and entrepreneurs a public forum, and which could support and promote their ideas.

Brewster had been taking an interest for some time in the problem of securing the rights of inventors. Apart from his own experience, he had apparently been involved in promoting other patent applications, including that of John Ruthven, an engineer who became Brewster's Edinburgh agent for the telescopic kaleidoscope, and whose patent printing press of 1815 became a commercial success.²⁶

Another example, and one which may finally have persuaded Brewster of the virtue of having some sort of influential patronage body, was Alexander Adie's invention in 1816 of a novel and extremely sensitive marine barometer. Christened the 'sympiesometer' – a name almost certainly proposed by Brewster to confer academic respectability and status – the device was successfully patented in 1818.²⁷ The instrument probably had its origins in work performed by Adie on glass capillary devices developed for John Leslie ten years beforehand. These had not been patented, but they had proved successful enough for a joint marketing venture to be set up with the London optician William Cary.²⁸ The sympiesometer was enthusiastically received and sold in large numbers over the period of patent protection, with Adie again licensing London agents.²⁹

The patronage structure that Brewster proposed was a Scottish analogue to the thriving London

'Society for the Encouragement of the Arts and Manufactures' – the present day Royal Society of Arts.³⁰ Brewster's 'Society for the Encouragement of the Useful Arts in Scotland' was launched in 1821 with the specific purpose of encouraging and rewarding Scottish inventors, and Brewster was outstandingly successful in enlisting the support of influential and aristocratic patrons (fig. 2).³¹ He positioned himself at the centre of a network of correspondents and technical committees as the Director of the Society.

At the same time as the Society of Arts was launched, Brewster also announced the establishment of the Edinburgh School of Arts.³² In this he acted in conjunction with Leonard Horner, the Edinburgh educationalist who a few years later was a founder of the University of London. The School of Arts was the first of the successful British mechanics' institutes, and when it opened in late 1821 it proved an immediate success with over 400 pupils registered in the first year. Indeed, so successful was it that Brewster was concerned that it would draw support away from his embryo Society of Arts, and he attempted to hijack the School in a bizarre episode that has been discussed by Steven Shapin.³³ Brewster was not successful in his attempt, and the School remained independent of the Society and continued to thrive, making a valuable contribution to technical education in the City. It ultimately developed into the Heriot Watt University.

Both institutions were being funded in the same way, by inviting financial subscriptions from the wealthy and influential, and Brewster's concern that the more socially elevated Society of Arts might suffer was probably real enough. The precedent for both schemes had presumably been the establishment of the Edinburgh Astronomical Institution in 1812 to raise support for building an observatory on Edinburgh's Calton Hill. The Institution, with the Prince Regent as Patron and Professor John Playfair as President, had Brewster as Secretary managing its affairs. Enough

SOCIETY OF ARTS FOR SCOTLAND.

OFFICE-BEARERS.

His MAJESTY the KING, PATRON.

PRESIDENTS.

His Grace the Duke of Atholl, K. T. F. R. S. &c.
 The Right Honourable the Earl of Wemyss and March, F. R. S. Edin.
 The Right Honourable the Earl of Hopetoun, G. C. B. F. R. S. Edin.
 The Right Honourable Lord Viscount Melville, F. R. S. Lond.
 The Right Honourable Lord John Campbell, M. P. F. R. S. Lond. and Edin. and M. R. I.
 The Right Honourable Lord Gray, F. R. S. Lond. and Edin.

VICE-PRESIDENTS.

The Right Honourable Sir Samuel Shepherd, Bart. Lord Chief Baron, F. R. S. Edin.
 The Honourable Captain Napier, R. N. F. R. S. Edin.
 Sir George Clerk, Bart. M. P. F. R. S. Lond. and Edin.
 Sir George Mackenzie, Bart. F. R. S. Lond. and Edin.

DIRECTOR.

David Brewster LL.D. F. R. S. Lond. and Sec. R. S. Edin.

TREASURER.

George Forbes, Esq. F. R. S. Edin.

SECRETARIES.

John Robison, Esq. F. R. S. Edin.
 Thomas Guthrie Wright, Esq. F. R. S. Edin.

EXTRAORDINARY COUNSELLORS.

<p>The Right Honourable David Boyle, Lord Justice Clerk, F. R. S. E. The Right Honourable William Adam, Lord Chief Commissioner, F. R. S. E. The Right Honourable Sir William Rae, Bart. Lord Advocate. Honourable Baron Clerk Rattray, F. R. S. E. Honourable Lord Meadowbank, F. R. S. E. Sir William Forbes, Bart. F. R. S. E. Sir John Hay, Bart. F. R. S. E. Sir James Hall, Bart. F. R. S. L. and F. Sir Thomas Dick Lauder, Bart. F. R. S. E. Right Hon. Sir John Sinclair, Bart. F. R. S. E. Sir Walter Scott, Bart. F. R. S. E. Sir A. Keith, Knight Marischal of Scotland.</p>	<p>Henry Jardine, Esq. F. R. S. E. Dr T. C. Hope, F. R. S. L. and E. Sir William Arbuthnot, Bart. F. R. S. E. Gilbert Laing Meason, Esq. F. R. S. E. Rev. Principal Baird, F. R. S. E. Gilbert Innes, Esq. F. R. S. E. John Clerk, Esq. F. R. S. E. Francis Jeffrey, Esq. C. G. S. Menteach, Esq. F. R. S. E. James Russell, Esq. F. R. S. E. Alexander Irving, Esq. F. R. S. E. J. A. Murray, Esq. John S. More, Esq. F. R. S. E. Thomas Allan, Esq. F. R. S. L. and E. Robert Ferguson, Esq. F. R. S. E.</p>
---	--

ORDINARY COUNSELLORS.

<p>James Hunter, Esq. F. R. S. E. James Skene, Esq. F. R. S. E. William Clerk, Esq. Thomas Sivright, Esq. F. R. S. E. Leonard Horner, Esq. F. R. S. L. and E. Rev. Dr Macknight, F. R. S. E. Rev. Dr Brunton, F. R. S. E. Rev. John Thomson, F. R. S. E. Rev. Robert Gordon. Professor Wallace, F. R. S. E. Professor Pillans, F. R. S. E. Thomas Telford, Esq. F. R. S. E. William Trotter, Esq. James Jardine, Esq. F. R. S. E. Robert Stevenson, Esq. F. R. S. E.</p>	<p>Sir Henry Raeburn, F. R. S. E. W. A. Cadell, Esq. F. R. S. E. Dr Keith, F. R. S. E. Andrew Waddell, Esq. F. R. S. E. Robert Bald, Esq. F. R. S. E. William Playfair, Esq. Dr Fyfe. Mr Galbraith. David Bridges, Esq. Jun. Mr Alexander Adie, F. R. S. E. Mr James Milne. Mr Robert Bryson. Mr John Ruthven. Mr Whitelaw.</p>
--	--

CORRESPONDING COUNCIL IN GLASGOW.

Henry Monteith, Esq. M. P. *President.*
 Charles Mackintosh, Esq. *Vice-President.*
 James Cleland, Esq. *Secretary and Treasurer.*

<p>James Ewing, Esq. Dr Meikleham. James Dennistoun, Esq. James Smith, Esq. Dr Hooker.</p>	<p>Alexr. Garden, Esq. Robert Dalgleish, Esq. Andrew Templeton, Esq. Dugald Bannatyne, Esq. William Dunn, Esq.</p>
--	--

Fig. 2. The Office-Bearers of the Society of Arts for Scotland. The influential supporters of David Brewster's Edinburgh Society listed in his June 1821 prospectus. (*Royal Scottish Society of Arts.*)

money had been raised to begin construction in 1818 to an acclaimed classical design by John Playfair's nephew, William Playfair. The observatory was created the 'Royal Observatory' during George IV's visit in 1822, but it was some years before its permanent instruments were received.³⁴ The civil engineer James Jardine conducted initial observations, and William Wallace acted as the Observer after his appointment as Professor of Mathematics in 1819.

In the extended period from mid 1821 to late 1822 when the Society of Arts began actually functioning, Brewster had to be sure that he could line up some good candidate inventions for the Society's initial considerations. One promising device, which he seems to have appreciated for its commercial potential, was a clever machine for making accurate copies of drawings or engravings – a type of pantograph – and it was submitted to Brewster by a young manufacturer from Mauchline in Ayrshire called Andrew Smith.

Brewster's initial enthusiasm for Smith's instrument can be gauged from the fact that he immediately gave it an impressive-sounding Greek name, reminiscent of the kaleidoscope and the sympiesometer and from now on it was called the *Apograph*. However, the issue of whether it was in fact a suitable candidate for the Society to promote soon became complex for Brewster. Complaints were made about the design having been plagiarised; and when William Wallace soon after produced a very different but superior copying machine called the *Eidograph*, there were allegations that his improved design had also been stolen by Smith. Brewster resolved this dilemma in the only way he could – by supporting his friend Wallace and largely ignoring Smith. A few years later, however, when Brewster's influence in the Society had substantially diminished, Wallace again found his instrument under attack, this time by a young and talented Edinburgh instrument maker called John Dunn. By now the Society's operations were more open and objective; and Wallace, unable to secure the

unequivocal support he demanded, resigned in high dudgeon.

THE PANTOGRAPH

Pantographs are drawing instruments, used to make copies of illustrations, and in particular to copy them at a reduced or enlarged scale. They take the form of four flat bars or arms, of brass or wood, jointed together to make a loose parallelogram. Two of the arms are short, with pivots at the ends; the other two are about twice as long and have one pivot at one end and the other near the centre. In the normal arrangement of the instrument the two long arms form adjacent sides of the parallelogram, so that the pantograph behaves like 'lazy tongs' (fig. 3).

Three similar socket fittings clamp to different arms of the pantograph. One attaches it to a weighted base, which locates the pantograph on a drawing surface, and around which the pantograph can rotate: small castor wheels are usually fitted at the pivots to enable it to do so. The other two take a tracer point and a pencil. Providing these three fittings are adjusted along the arms of the pantograph so that they are clamped exactly in line with each other (this is done by setting them against scales engraved on the arms), the geometry of the parallelogram is such that they will always remain in line regardless of how the pantograph is moved. If the tracer point is taken round the outline of a drawing, the pencil will reproduce it at a scale which is determined by the ratio of the distances of these two points from the pivot of the base. If the fixed base is attached to the middle fitting, then comparatively small enlargement or reduction ratios are obtained; larger ratios are achieved when it is in one of the other two positions.

The first published description of the pantograph is usually claimed to be one of 1631 by the Jesuit astronomer Christoph Scheiner.³⁵ Although the instrument was refined in the eighteenth century, it suffered from a number of mechanical defects which made it unsuitable for precision work. In particular, the

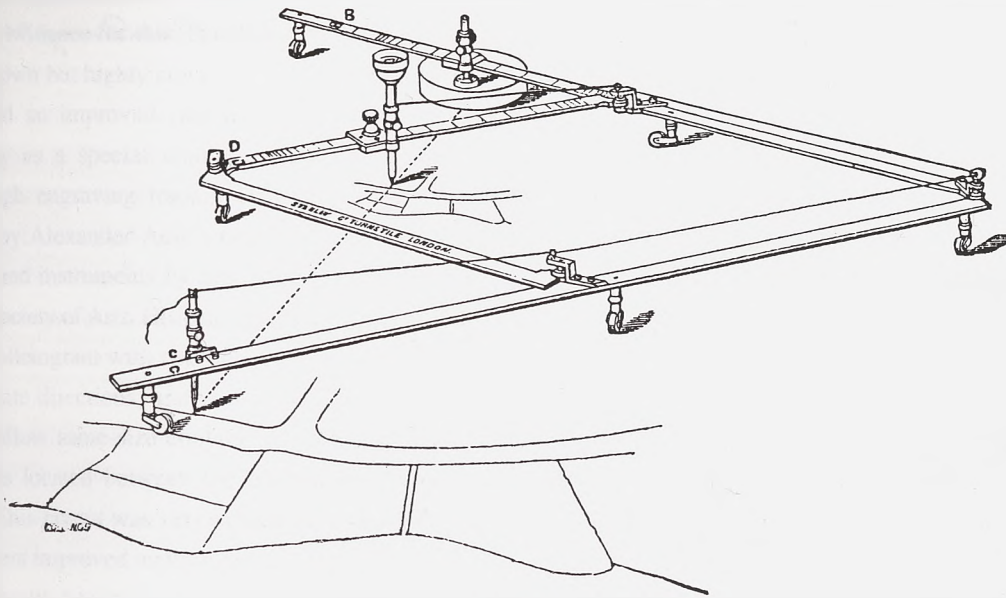

Fig. 3. A Pantograph in use, producing a reduced copy of a plan. Wood-block engraving from W. F. Stanley, *Drawing Instruments*, London 1878. (National Museums of Scotland.)

weight is unevenly distributed and has to be carried by castors, and there is inevitably a certain amount of play as well as friction in the various joints. As a result it is difficult to get the tracer to follow an outline smoothly, and the pencil does not move accurately in response to reversals in direction of the tracer.

In practice artists, engravers and cartographers preferred to use more laborious and traditional methods for transferring illustrations.³⁶ The simplest method was to divide the paper on which the original illustration was drawn into small squares, and then copy the lines within each one to a sheet which had been similarly divided, but to the required scale. A regular design could be transferred using proportional dividers, or the scales on a sector, to obtain a particular magnification. Copying to the same scale was often done using a type of tracing paper. All these however were very labour intensive.

It was inevitable that attention would eventually turn to improving the pantograph. When new

instruments did appear in the 1820s they were taken up with enthusiasm by engravers and cartographers, particularly those working on the preparation of plates for serial publications, which were often composites of small illustrations. William Wallace, when describing his own instrument in 1831, noted the demand for accurate reduced copies: 'This is by far the most common case at the present time, when numberless Encyclopaedias, Atlases, and other works illustrated by figures, are in progress of publication, the materials of which are, for the most part, taken from writers of established eminence'.³⁷ But there were other areas where substantial levels of reduction were necessary, and the special needs of medallist artists and seal engravers were much in the minds of the promoters of these instruments.³⁸ An added advantage was the ability to make the copy directly on the printing plate with an engraving point held in the copying machine so that the plate could be etched with less preparation.

The Apograph. Invented by And^r Smith, for copying on any scale of reduction. Pictures, Drawings, &c.

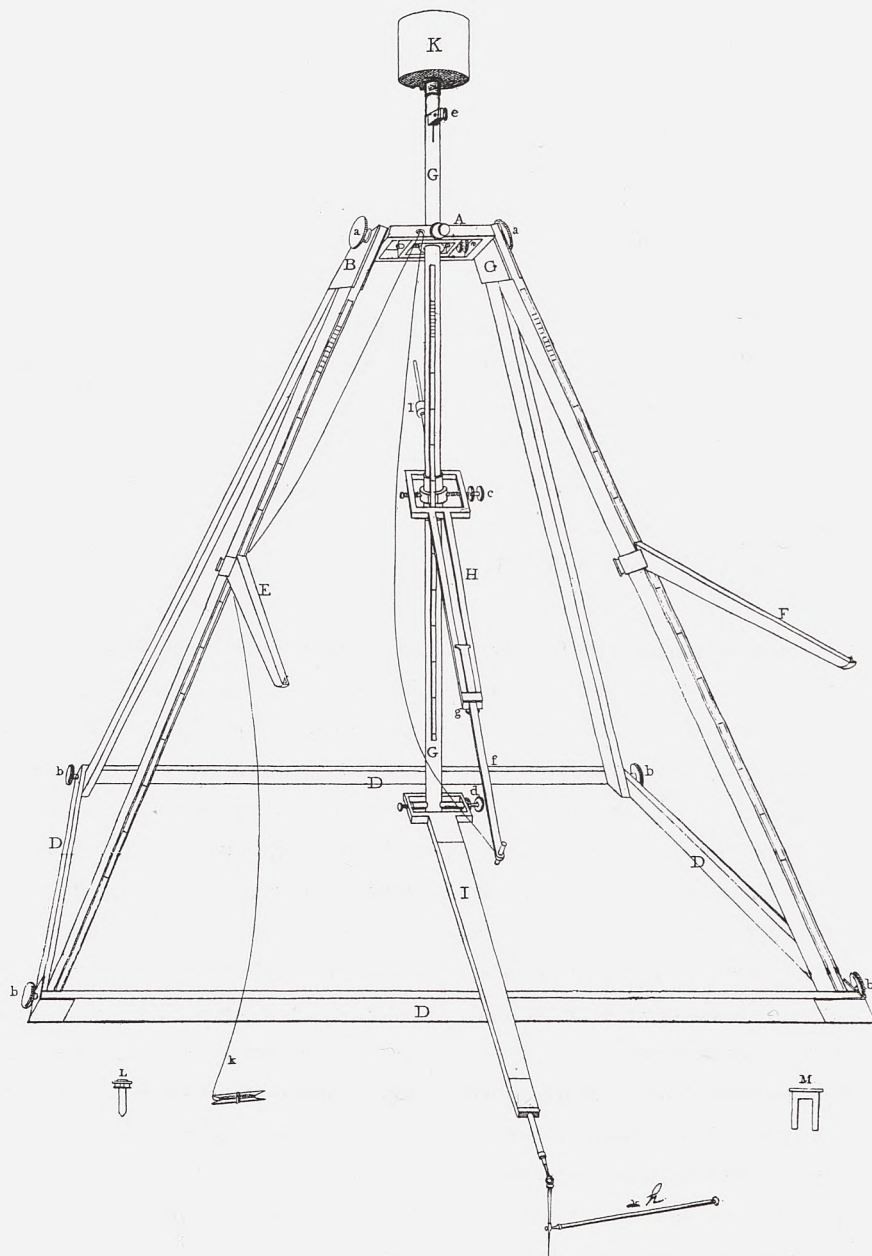

Fig. 4. Andrew Smith's Apograph, for producing reduced copies. A pencil at the end of the counterbalanced arm H rests on the top or bottom surface of a drawing board placed on the horizontal arms E and F. Engraving from Smith publicity material, c. 1822. (National Museums of Scotland; papers with T1976.66.)

It might be expected that there would be a period of some experimentation beforehand, and indeed there is some evidence for this. Peter Hill of Edinburgh, a little known but highly competent instrument maker, produced an improved pantograph in about 1810, probably as a special commission for use in the Edinburgh engraving trade.³⁹ Hill may have been trained by Alexander Adie's uncle and partner John Miller, and instruments by him were later examined by the Society of Arts. His pantograph was in the form of a parallelogram with two opposing sides extended in opposite directions, and with an extension to one arm to allow same-size copying when the weighted base was located between the tracing and copying points. This layout was very similar to several of the subsequent improved instruments.

ANDREW SMITH AND THE APOGRAPH

The first of the improved pantographs in this dispute to emerge in public was the one produced by Andrew Smith. The Smith family business was a factory in Mauchline, Ayrshire, making stone 'hones' for sharpening razors, but Andrew was a restless entrepreneur who soon diversified into woodware, transfer printing and other fields, ultimately with a string of inventions to his name and running a second factory in Birmingham.⁴⁰ The firm made a great success of manufacturing fancy woodware and decorative boxes analogous to English Tunbridge-ware. However, the commercial success of W. & A. Smith, and other local manufacturers, soon brought Mauchline-ware to similar prominence.

The copying machine was Andrew Smith's first venture outside the family firm's normal product range. Its first public appearance was apparently at a meeting of the Glasgow Philosophical Society on 12 March 1821, where it was described merely as Smith's 'Tracer'.⁴¹ It may have been drawn to David Brewster's attention, or Smith may have been given an introduction to Brewster. Certainly, Brewster's contacts with Glasgow were very good at this time

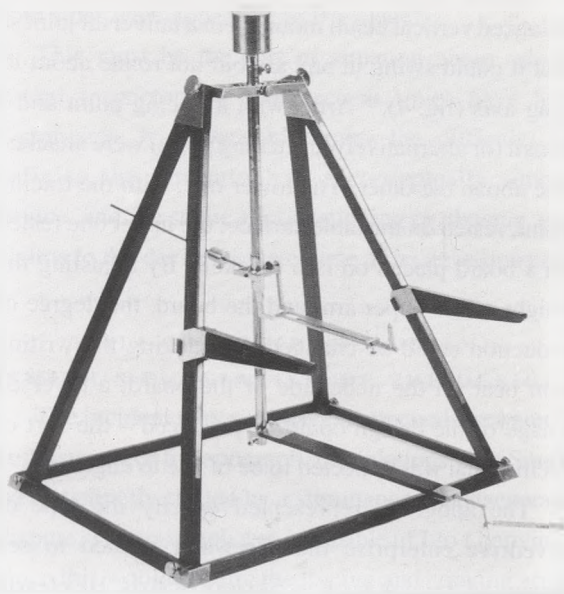

Fig. 5. Andrew Smith's Apograph, c. 1822. This example in the Royal Museum of Scotland was originally in the possession of the Earl Spencer. The overall height is 62 cm. (*National Museums of Scotland; T1976.66.*)

because he was setting up a 'Corresponding Committee' in Glasgow for the Society of Arts, the Secretary of which was the statistician James Cleland.⁴²

Smith brought his instrument to Edinburgh in April 1821 and demonstrated it privately to Brewster and some of his friends.⁴³ One of these was Sir George Mackenzie, who had been Vice-President of the Astronomical Institution, becoming President after Playfair's death, and was also a Vice-President designate of Brewster's Society of Arts. Mackenzie was a mineralogist who had distinguished himself by demonstrating, under combustion with iron, that diamond is an allotropic form of carbon, making free use (or so it was said) of his mother's diamonds in the process.⁴⁴ Doubtless he and Brewster agreed between them that Smith's instrument was a promising candidate for the Society's patronage.

Brewster's first act seems to have been giving the 'Tracer' the dignity of a scientific name. The

Apograph, as Brewster named it, had a counter-balanced vertical beam mounted in a universal joint so that it could swing in any arc but not rotate about its long axis (fig. 4).⁴⁵ Arms with a tracing point and a pencil (or alternatively an etching point) were attached one above the other. The lower one, with the tracing point, rested on the table surface; the upper one rested on a board placed on two brackets. By adjusting the height of the upper arm and the board, the degree of reduction could be changed. By making the writing arm bear on the underside of the board, a reversed image of the design could be produced – the sort of facility that was expected to be of use to engravers.

The apograph represented exactly the type of inventive enterprise that Brewster wished to see promoted through his new Society of Arts. He clearly persuaded Smith that it should be one of the first inventions that the Society would consider, and that he himself would also publish a proper description of it in his *Edinburgh Philosophical Journal* to secure Smith's priority.⁴⁶

The Society of Arts however had not yet been publicly launched. Brewster was to do so with some razzmatazz two months later, in June 1821, with himself as Director, the newly-crowned King George IV as patron, and with a galaxy of presidents, vice-presidents and councillors (fig. 2). Perhaps more with the intention of keeping Smith on a string, Brewster proposed that he should seek financial encouragement for him from the Government's Board of Trustees for Manufactures in Scotland.⁴⁷

Initially, however, he wrote Smith a letter of commendation which Smith took the next day to a meeting of the Wernerian Natural History Society, where he gathered more signatures and lined up further sales.⁴⁸ One of the sales that Smith made was to the civil engineer Robert Stevenson. Another was to W. H. Lizars, the talented artist, and engraver to the Royal Society of Edinburgh, who was soon using it professionally, as was his senior journeyman George

Bartholomew (father of John Bartholomew who founded the famous cartographic firm).⁴⁹ Brewster himself would not attend a Wernerian meeting as he was then involved in a bitter dispute with its president Robert Jameson, who was his co-editor of the *Philosophical Journal*.⁵⁰ However, Jameson did add his signature to Brewster's letter of commendation at the meeting, as did William Wallace, whose involvement now becomes of some interest.

In May, Smith sent Brewster an improved and more polished version of the apograph, with the news that his brother William had had some success with it in London. He had gone south armed with two introductions. The first, from Sir George Mackenzie, was to the Admiralty and thence to the Board of Ordnance, which had given the Smiths their first prestige sale.⁵¹ The second letter was a recommendation from Brewster to Robert Bate, one of the prominent scientific instrument makers of the day, and the man to whom Brewster had earlier entrusted the manufacture of his polyangular kaleidoscope. Bate thought the apograph patentable and offered to finance the patent and production costs.⁵²

This posed a problem for Smith: if the instrument was patented at this stage, it would not be eligible for premiums from the Society of Arts or the Board of Manufactures. Smith needed the prestige that these awards would confer, but hopefully asked Brewster if taking out an English patent and not a Scottish patent might be acceptable. Brewster, who was equally anxious that the apograph should be reserved for the Society to handle, counselled caution, and the patent was apparently not pursued.

Brewster also warned Smith of the danger of allowing a premature account to be published, before an adequate technical description appeared – that is, before he could scoop the device in his own *Journal*. But the dispute with Jameson was posing serious production problems for the *Journal's* publisher, and Brewster soon found the story was out anyway.

Smith's local paper, the *Ayr Advertiser*, had held the story back at his request, but published on 19 July when it was rumoured that the rival *Courier* was about to carry a similar piece.⁵³

SMITH OR REID AS THE INVENTOR?

Andrew Smith could now appreciate the force of Brewster's warning about premature disclosure. Within a week the *Advertiser* had published a letter from another claimant to the invention.⁵⁴ This public correspondence continued with such vigour that in September Smith felt obliged to write to Brewster to say that he was now engaged in a 'contest with a fellow here' over priority, and to ask what he should do.⁵⁵

The essence of the 'contest' was that Thomas Reid, the school-master in Tarbolton, a village a few miles from Smith's home, claimed to have invented the apograph only to have it stolen from him. It seems that he did indeed hit on the principle, and made the first crude device, and that Smith was able to deduce and copy its construction from the description that Reid gave him.⁵⁶

However, Smith made some important improvements. In particular, he introduced the universal joint where Reid had used a rather makeshift device that prevented rotation. Reid saw the improved version and asked Smith if he would arrange for one to be made for him.⁵⁷ Reid of course subsequently described this as his invention, although he admitted that his particular example was made by Smith.⁵⁸ Smith clearly saw the improvements (to which Reid made no claim) as the important aspects and by avoiding discussing Reid's original instrument he reserved the invention to himself.⁵⁹ Claim and counter-claim became more difficult to assess as evidence was gathered and affidavits sworn. The rival newspapers took sides, and Smith's much more substantial patrons weighed in on his side and even attempted to intimidate Reid.⁶⁰ Smith tried to trivialise the affair (and clearly survived it unscathed) but by

February 1822 legal action was being threatened and both sides were appealing to Brewster.⁶¹

This must be the sort of situation about which patent inspectors of more recent times have had nightmares. It at once highlights the difficulty of defining the 'invention' of a conceptually simple device, and the scope for questioning or abusing any claims to the device in the course of its development.

WALLACE'S EIDOGRAPH AND SMITH'S PLAGIARISM OF THE DESIGN

The incident may well have dampened Brewster's enthusiasm for the apograph, but relations with Smith were distinctly chilled by a simultaneous but separate dispute. The apograph was incapable of 1 to 1 copying, since this would require the tracing and copying arms to coincide. When Andrew Smith had first written to Brewster in September 1821 of his 'contest' with Reid, he had described how he had overcome this not-inconsiderable shortcoming by devising a new form of pantograph, which he illustrated in his letter (fig. 6).⁶² What he did not know was that William Wallace, a close friend of Brewster, had developed a similar instrument and was able to demonstrate to Brewster that Smith was likely to have stolen his design.⁶³

Wallace, a few years Brewster's senior, was a very able mathematician who had risen from comparatively humble positions in the Edinburgh publishing trade, and with the support of Robison and Playfair had found a variety of mathematical employments, latterly that of lecturer at the new Royal Military College, which was then at Great Marlow in Buckinghamshire.⁶⁴ With the death of Playfair in 1819, Wallace came north again to fill the coveted Mathematics chair at Edinburgh. Like Brewster, Wallace was a family man who lived well beyond his regular means and like Brewster he was forced to rely on his scientific writing to pay the bills: in particular he was a regular contributor to paying ventures such

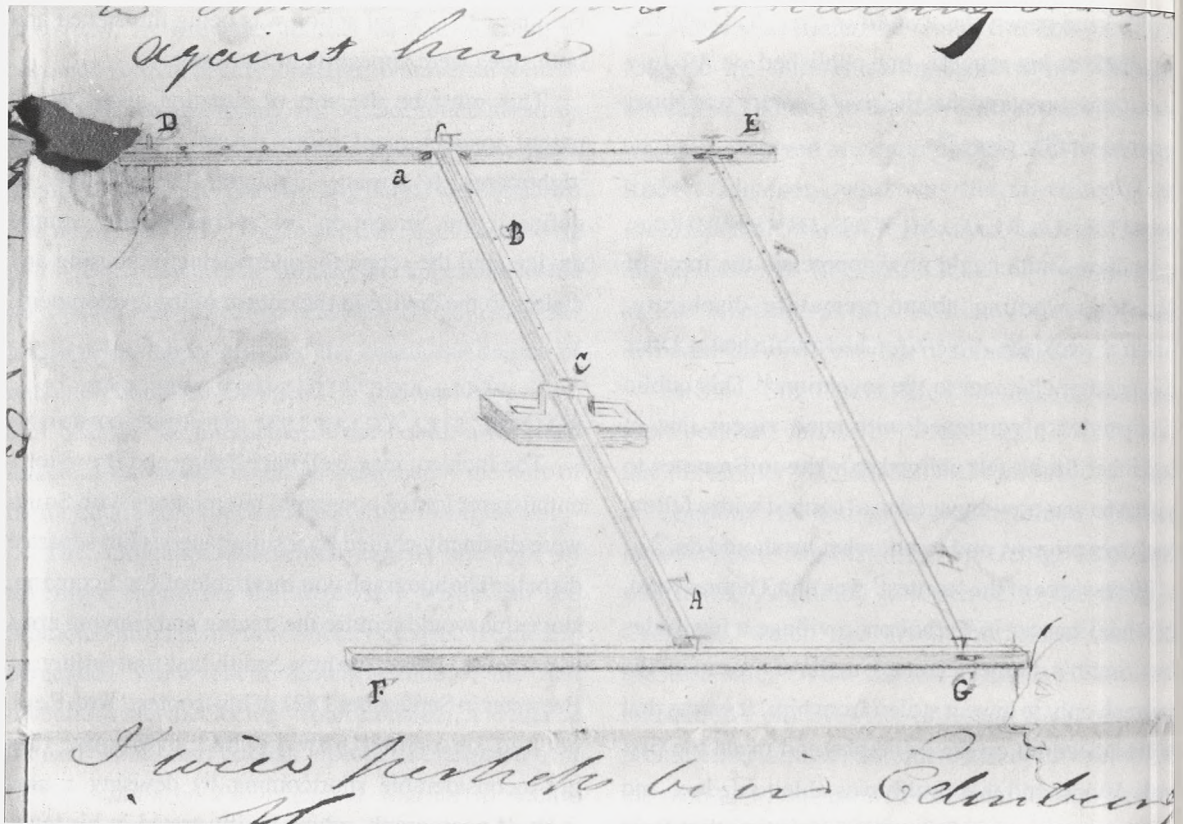

Fig. 6. Drawing by Andrew Smith of a new form of pantograph for copying drawings. From a letter to David Brewster, 13 September 1821. (National Library of Scotland; Acc. 4534/3; (1821).)

as the *Encyclopaedia Britannica* and the *Edinburgh Encyclopaedia*.⁶⁵

Although Wallace had signed Andrew Smith's testimonial for the apograph at the April meeting of the Wernerian Society, he had made a point of calling on Smith two or three days later to express his strong reservations about the device.⁶⁶ Wallace never admitted as much, but this was the 'particular circumstance' that he later said had turned his own attention to improving the available copying instruments.⁶⁷

Wallace returned to the more familiar horizontal scheme of the pantograph, discounting the unnecessary complication of operating at two heights, which was a serious restriction on the utility of the apograph. Encouraged by his friend the civil engineer James Jardine, Wallace re-engineered it in such a way

as to remove its mechanical defects.⁶⁸ Two forms were developed. The simpler one made enlarged or reduced direct copies; but influenced by the requirements of engraving he also had a prototype made of a more complex design which generated a reversed copy. The discussion below relates to the simple, or direct copying version, which was the one that subsequently came into widespread use.

Like the pantograph, the *Eidograph* (as Wallace christened it) had a weighted anchor, and linked tracing and copying points, and it depended for its operation on these remaining accurately parallel; but here the ingenious feature was to replace linkage bars with a fusee chain taken around two wheels to ensure the parallelism of the arms (fig. 7).⁶⁹

The weighted base of the eidograph was positioned between the tracing and copying points, and the

instrument mounted on a well made bearing: since it was very nearly in balance it did not require the support of castors. The replacement of the parallelogram of the pantograph framework by the wheels and chain of the eidograph meant that the mechanical advantage exerted between tracing and copying points was always the same and was not dependent on the angles between component parts.

By July 1821 Wallace was showing the eidograph's paces to selected friends. One of his patrons was the senior judge Lord Glenlee, who was also a mathematician of some note and a distinguished figure in the Royal Society of Edinburgh; a particular reason why Wallace might have wished to cultivate him was that Glenlee was a member of the Board of Manufactures.⁷⁰ Glenlee was also known to Andrew Smith, and Smith had already signalled his hope to Brewster that Glenlee would support the apograph when Brewster placed it before the Board.⁷¹ Glenlee had retired for the summer months to his country seat at Barskimming, Ayrshire, and when Wallace called on him, Glenlee suggested he should also show the

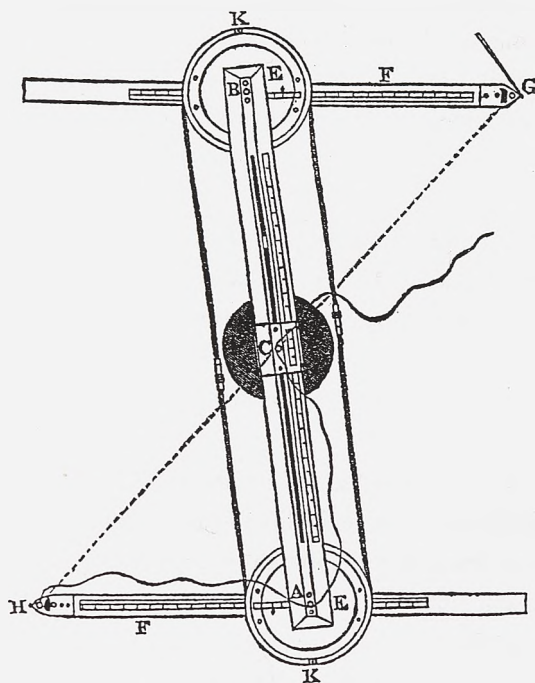

Fig. 7. William Wallace's Eidograph as made by R. B. Bate of London, 1822. Wood-block engraved plan-view of the instrument from the *Encyclopaedia Britannica Supplement* of 1824. (*National Museums of Scotland.*)

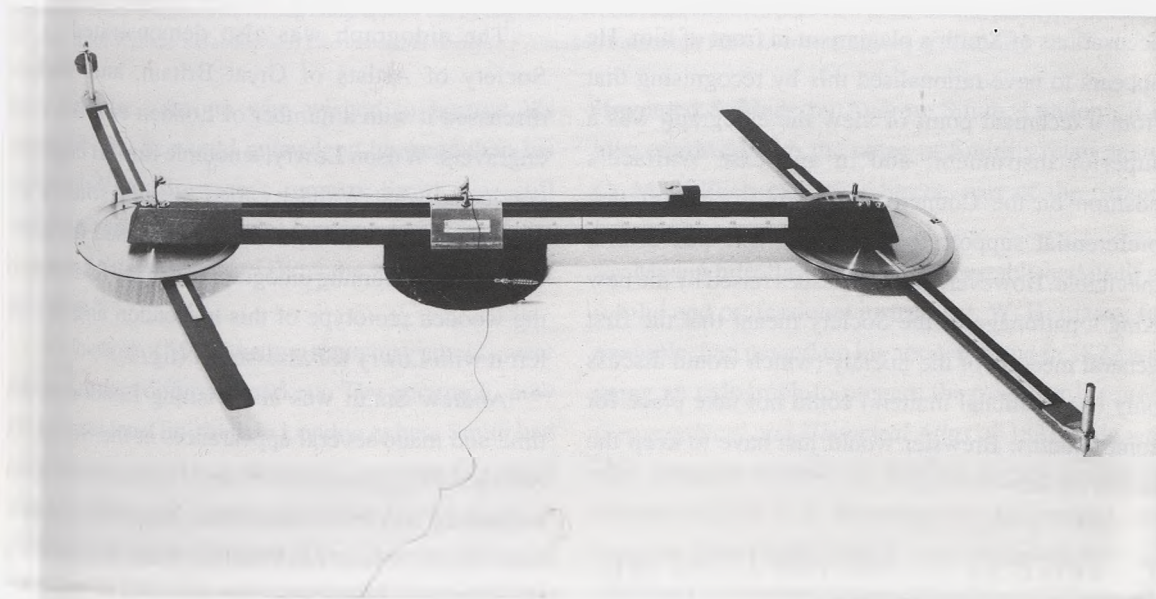

Fig. 8. William Wallace's Eidograph. R. B. Bate's sixth instrument, c. 1822, latterly used for cartographic work by John Bartholomew & Son. The original chain has been replaced by a steel band. The distance between the wheel centres is 63.5 cm. (*National Museums of Scotland; T1967.140.*)

eidograph to his neighbour Sir Alexander Boswell of Auchinleck.⁷² The son of the famous chronicler of Samuel Johnson, Boswell was a publisher and a prominent member of Edinburgh literary circles. He also was known to Andrew Smith (although Wallace was not aware of this) and indeed a month later became one of Smith's supporters in the contest with Thomas Reid.⁷³ The upshot of Wallace's visit was that a simplified version of the eidograph design (omitting the wheels) was passed to Smith who, not appreciating a connection with anyone of note, developed it as his own.

At the end of the 1821 summer recess, Wallace demonstrated the versatility of his new device at the Royal Society of Edinburgh on 5 November 1821.⁷⁴ Brewster had drawn his attention to Smith's new design, and Wallace was soon incensed to discover the sequence of events that he believed led to the invention being pirated.⁷⁵

Brewster was placed in a quandary over whether the Society of Arts should still be encouraged to support Smith's apograph: his sympathy was clearly with Wallace, and he now had two independent accusations of Smith's plagiarism in front of him. He appears to have rationalised this by recognising that from a technical point of view the eidograph was a superior instrument; and in any case Wallace's position on the Council of the Society meant that preferential support for the eidograph was almost inevitable. However, protocol issues raised by the new King's patronage of the Society meant that the first general meeting of the Society (which would discuss only constitutional matters) could not take place for some months: Brewster would just have to keep the matter on ice.

SEEKING SALES FOR THE APOGRAPH AND EIDOGRAPH

In the meantime neither Smith nor Wallace were inactive. Wallace was fortunate in having the

friendship of Robert Dundas, Viscount Melville, who was MP for the County of Edinburgh, but was also First Lord of the Admiralty and one of the six Presidents of the Edinburgh Society of Arts. Wallace had through Brewster obtained the services of the London instrument maker Robert Bate, who produced for him a better engineered version of the simple form of eidograph (fig. 8).⁷⁶ Lord Melville now arranged for two eidographs to be supplied to Captain William Owen, who sailed in February 1822 on a protracted hydrographic voyage round the African coast – the first independent trial of the eidograph, and an important step forward for Wallace.⁷⁷

In the summer of 1822 William Wallace and his son Alexander went on a promotional trip to the south, demonstrating the eidograph at 'almost all the Public Establishments ... where charts and plans are constructed' and at a number of military and naval institutions, including the Royal Military College where he himself had taught a few years before.⁷⁸ Bate was instructed to provide eidographs for all the institutions where it was exhibited and well received, a number of these presumably at Wallace's expense.

The eidograph was also demonstrated at the Society of Artists of Great Britain, and Wallace discussed it with a number of London engineers and engravers. Wilson Lowry, a notable fine art engraver, conducted what Wallace called 'a slight trial' of the eidograph, but in particular they discussed the likely value of the reversing eidograph. Wallace had brought the wooden prototype of this to London and he now left it with Lowry for assessment (fig. 9).⁷⁹

Andrew Smith was also visiting London at this time and made several appearances at the Society of Artists with the apograph.⁸⁰ One of his most prominent supporters was the controversial artist and engraver John Martin, whose most famous work 'Balshazzar's Feast' had appeared the previous year.⁸¹ The artist Charles Muss, a notable enamel- and glass-painter and a close friend of Martin, was extravagantly reported to

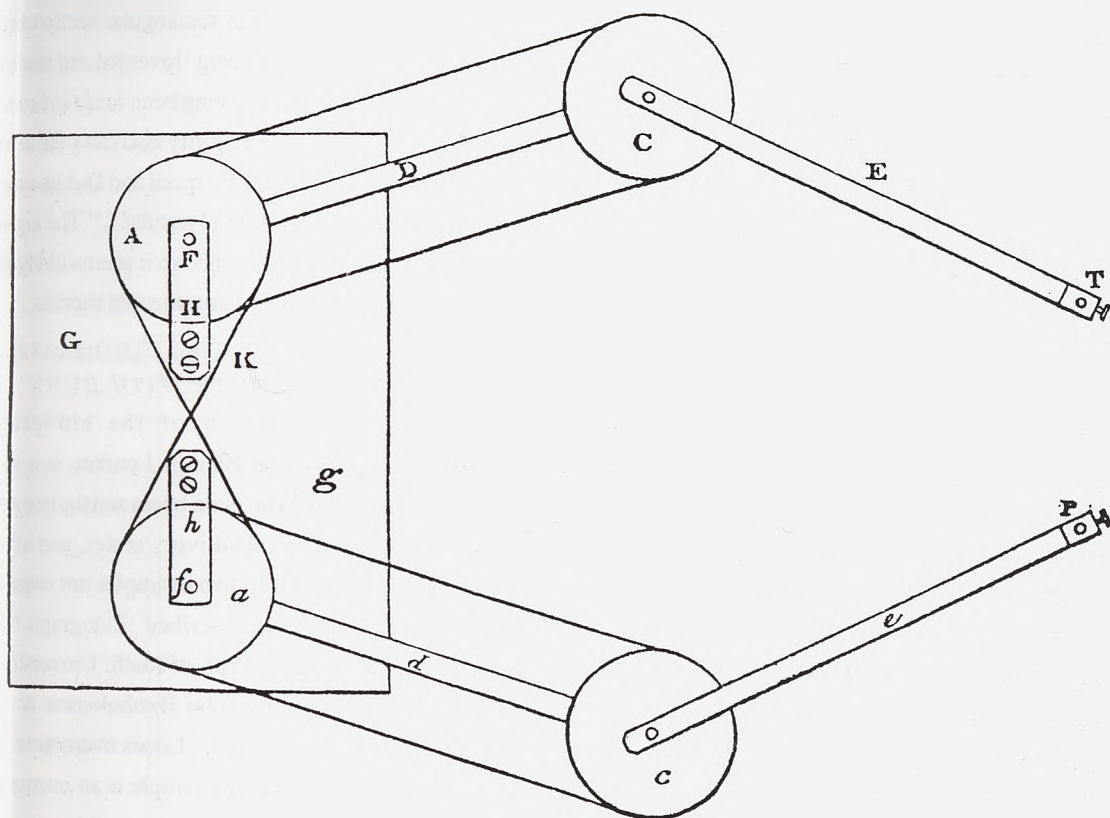

Fig. 9. William Wallace's Reversing Edograph for use by engravers. Wood-block engraved plan-view of the wooden prototype instrument of 1821, from Wallace's *Geometrical Theorems and Analytic Formulae*, Edinburgh 1839. (National Library of Scotland.)

have said to someone who wished to borrow his apograph that he would rather lend his head than his apograph.⁸² At Brewster's request, Smith was still resisting requests in early January 1823 from the London Society of Arts to show the apograph at their meetings.⁸³

By the end of 1822, the two main instruments were finding rather different markets. The apograph, now made (or at least finished) in London, where Smith had temporarily settled to promote it, appealed to a more dilettante market.⁸⁴ The one example known to me in Britain, now in the collection of the National Museums of Scotland (fig. 5), was purchased (apparently in 1822) by the Earl Spencer, indicating some success in promoting the device. Although it is engraved as being

'Invented & Made by Andrew Smith, London', it is also engraved with the name of Smith's retail agent, C. M. Willich of Picket Street, part of the Strand, London.⁸⁵

Meanwhile, the eidograph had established itself as a solid and professional instrument. W. H. Lizars, for example, had passed up his apograph and in 1822 was using an eidograph to prepare the maps for his great *Geographical and Historical Atlas* of 1831.⁸⁶ He was also using it extensively for the highly acclaimed illustrations he was preparing for his brother, the surgeon John Lizars, which were published between 1823 and 1826 as his *System of Anatomical Plates* and which remained the standard anatomical atlas for much of the century.⁸⁷

ASSESSMENT AT THE
SOCIETY OF ARTS

At long last by December 1822 the Society of Arts had an agreed constitution and had begun to function properly. Amongst the first group of items considered by the Mechanical Arts Committee at meetings in late December and early January were the eidograph and the apograph.⁸⁸ The Committee included Wallace, Jardine and Brewster, and so it should come as no surprise that the eidograph was 'applauded as being of great importance', whereas the apograph was merely 'viewed'.⁸⁹ The suspicion must be that only the eidograph was shown at the general meeting of the Society on 17 March 1823 when the 'most important' items considered by the Committee were exhibited.⁹⁰ No commendation of the apograph is recorded as being issued by the Society, although Smith was pressing for this. I can find no record of Brewster laying it before the Board of Manufactures for a premium, nor did he publish the promised account in his *Journal*.⁹¹ By contrast, when the Society instituted its gold medal in 1825, Wallace was its first recipient, and the award was made for the invention of the eidograph.⁹²

The eventual fate of the apograph is unknown. W. & A. Smith contributed an apograph, together with examples of their decorative wooden boxes, to an exhibition of 'Models and Manufactures, &c.' put together for the 1840 Glasgow meeting of the British Association for the Advancement of Science. If there was any doubt that the apograph was still being promoted by the firm, the catalogue of the exhibition dispells this: 'A person is in constant attendance to exhibit this instrument at work'.⁹³

The simple pantograph instrument that Smith had described in his September 1821 letter to Brewster was also produced commercially. It is not known when it was launched, but there is an undated illustrated instruction sheet for Smith's 'New Pantograph or Tracing Instrument' on 1830-watermarked paper

(fig. 10).⁹⁴ Several of these instruments have come to light: all are constructed in rectangular-section brass tube and are engraved as being 'Invented and made by W. & A. Smith', perhaps having been made in Smith's Birmingham works. The majority also carry the names of retail agents (London, Liverpool and Dublin names have been recorded) and serial numbers.⁹⁵ The highest number I have recorded is 483, so it seems likely that the New Pantograph was a commercial success.

ADIE'S FORM OF THE EIDOGRAPH
AND THE DISPUTE WITH DUNN

The original version of the eidograph, manufactured by Robert Bate in London, is a most attractive instrument. The main beam and the two arms are in mahogany with inlaid ivory scales, and all the fittings are in brass. Only two examples are recorded at present. One of these, inscribed 'Eidograph N.º 6 Invented by W. Wallace Prof: of Math: University of Edinburgh', was used by John Bartholomew & Son (fig. 8), and may have been the Lizars instrument.⁹⁶ A second and slightly smaller example is an instrument with the serial number '2', which is possibly one of the eidographs placed by Wallace as a result of his 1822 sales trip.⁹⁷

The first published description of the eidograph appeared in April 1823 in the article 'Pantograph' (almost certainly contributed by Wallace) in the *Supplement to the Fourth, Fifth and Sixth Editions of the Encyclopaedia Britannica*, in which Bate was advertised as the supplier.⁹⁸ However, it seems unlikely that he was in a position to manufacture it for long. In 1824 and for the following few years, he was very heavily involved with a lucrative contract with the Treasury and the Board of Trade for the development and supply of large quantities of the new Imperial Standards of weights and measures; this placed him under considerable pressure and other business was ignored in the process.⁹⁹

Wallace's response was to commission Alexander Adie to produce and market a new version. Adie's

THE NEW PANTOGRAPH, OR TRACING INSTRUMENT.

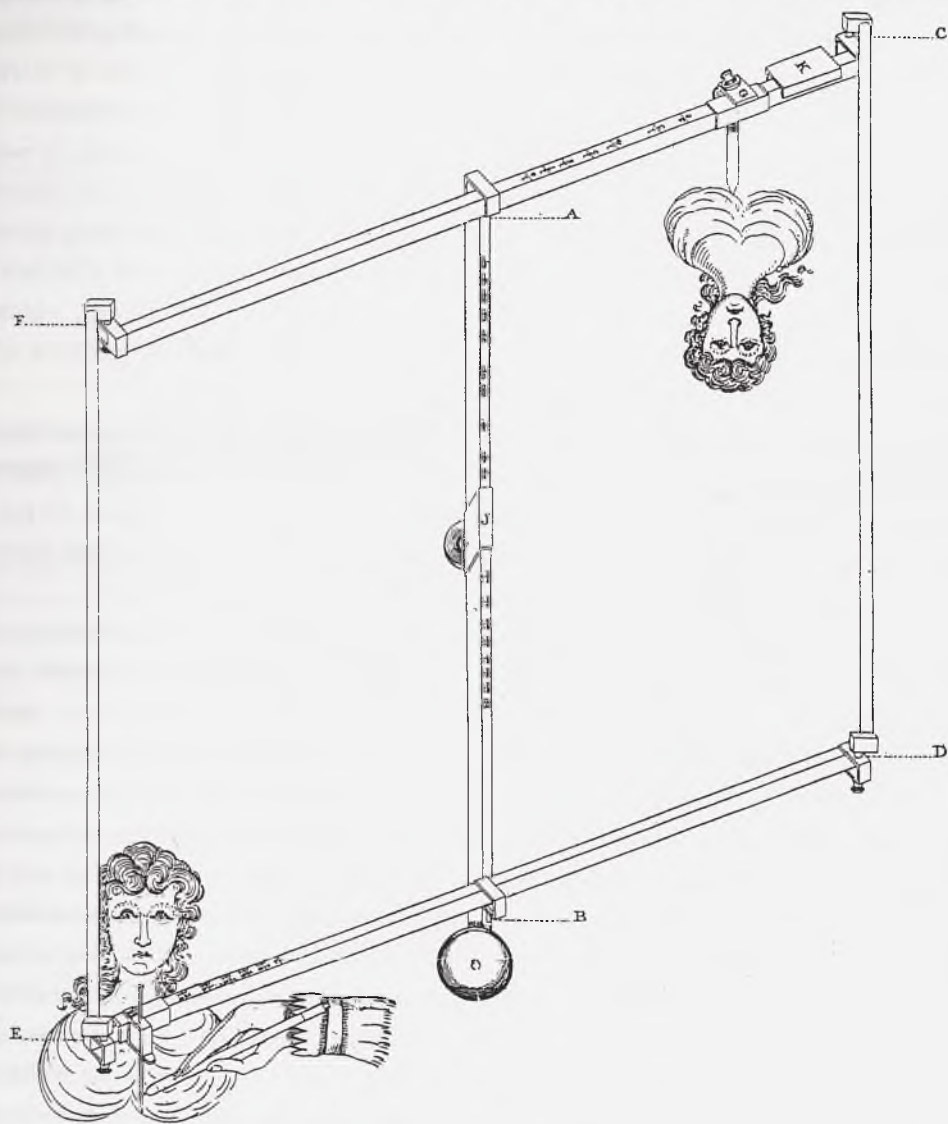

INVENTED, PATENTED, & MADE BY W. & A. SMITH.

For copying with ease and precision upon any required scale, Pictures, Drawings &c. &c.

Fig. 10. Andrew Smith's New Pantograph, c. 1830. Engraved illustration from the instructions for a Smith pantograph at the Science Museum, London. (Trustees of the Science Museum: papers with 1980-1162.)

Edinburgh instrument-making business had moved from strength to strength. From the mid 1820s he was capably supported by his oldest son John, who was doing significant work by 1828, and who went into

partnership with his father in 1835.¹⁰⁰ Bate's eidograph was given the 'Adie treatment' and emerged as a sophisticated device, completely re-engineered in strong but lightweight precision brass tube. The

approach was characteristic of John Adie and it is tempting to think that the design was largely due to him. Certainly, John signed the bill for the eidograph made in 1830 for that discerning customer, the civil engineer Thomas Telford.¹⁰¹ The special square-section brass tube, which was so important to the success of the new eidograph and which figures in many Adie precision instruments from this date, was probably the result of collaboration with the Edinburgh master brass-founder James Milne, another prominent member of the Society of Arts.¹⁰²

The new eidograph was probably developed in 1828. The date of its launch is not known, but it was demonstrated to the Society of Arts in June 1829.¹⁰³ From now on it was manufactured only by Adie, and although the later instruments do not carry serial numbers, it is clear that a considerable number were produced. Like the apograph, the eidograph was also exhibited at the 1840 Glasgow exhibition for the British Association.¹⁰⁴ It was submitted by Wallace himself rather than by the Adie business, but he also submitted another product of his collaboration with Adie. This was the 'chorograph', a form of surveying protractor designed for triangulation calculations, invented by Wallace in 1839 and manufactured by Adie. The chorograph was advertised as being available also from the London firm of Troughton & Simms who were instrument makers to the Ordnance Survey.¹⁰⁵ Adie also sold the eidograph on a wholesale basis, and examples survive with the signatures of Glasgow, London and Birmingham retailers.¹⁰⁶

At this point I must introduce the final protagonist in this dispute, the young Edinburgh philosophical instrument maker John Dunn, who had attended early sessions of the School of Arts.¹⁰⁷ When Dunn was elected to the Society of Arts in 1828, after only four years in business, he had an enviable reputation and had for example already executed commissions for London University. In December 1829 he submitted a paper to the Society in which he described his

'Improved Pentograph' which purported to include improvements on Wallace's eidograph.¹⁰⁸ Dunn had in fact found a weakness in the eidograph's design: if the chain had any tendency to slip in its clamps the parallelism was lost, and so the instrument had to be frequently inspected and adjusted. To remove this difficulty and simplify the construction, Dunn dispensed with the wheels and chain, and substituted a single solid linkage bar, held at its ends in rather sophisticated conical bearings, which largely eliminated the mechanical problems of the old pantograph joints (fig. 11).

Because of the expense both of this instrument and of the more complex eidograph, Dunn had also produced a cheaper form in wood for less exacting work, and it now transpired that this form had been available for at least 18 months.¹⁰⁹

The Reporting Committee (which included the engineers James Jardine and his more conspicuous colleague Robert Stevenson) was placed in an awkward position in deciding whether to endorse Dunn's claims or not and this embarrassment is clearly shown in repeated postponements of their report.¹¹⁰ By a majority decision they decided to seek Wallace's view. Wallace, now approaching retirement forced by ill-health, clearly blew a fuse when he read Dunn's paper. His response was tactfully not retained in the Society's correspondence, but fortunately a transcript was preserved elsewhere.¹¹¹ In it Wallace rails on for 35 pages, insisting that a slight to his eidograph was intended and that Dunn's pentograph is no improvement – on the contrary it is worse and dangerously so. As Dunn was clearly selling the pentograph, Wallace ends by asking whether the Committee feel 'any difficulty in saying to whom Mr Dunn was indebted for the pecuniary advantage which he seems to enjoy from the construction of his instrument?'

The Committee eventually ruled that Dunn had effected only an alteration in the form of the

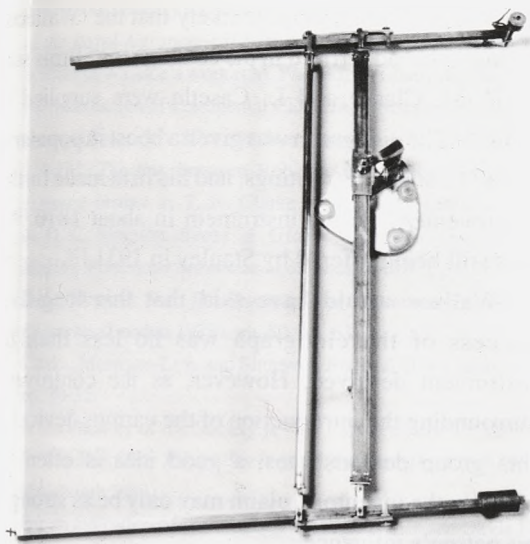

Fig. 11. John Dunn's Pentograph. An unnumbered example made in 1844, after John Dunn's death, by his brother and former partner Thomas Dunn of Edinburgh. The distance between the two pivots is 81 cm. (*National Museums of Scotland; T1948.X8.*)

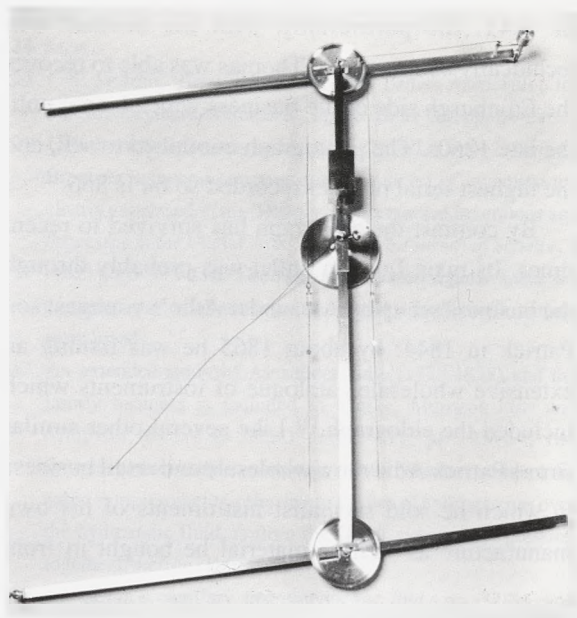

Fig. 12. William Wallace's Eidograph, by Alexander Adie of Edinburgh. The final form of Adie's re-engineered instrument. This example of c. 1850 was used by John Bartholomew & Son, Edinburgh. The distance between the wheel centres is 76 cm. (*National Museums of Scotland; T1967.141.*)

eidograph: it was not an improvement nor was it better. However, this was qualified by a minority report that if not actually better, it was at least equal to the eidograph.¹¹²

But Dunn's criticism had found its mark, and Wallace quickly had the chain replaced with a specially secured steel band.¹¹³ To consolidate his position he now showed this version at the Royal Society of Edinburgh in January 1831, and published a description in their *Transactions* with a history of the pantograph, darkly referring only to misguided attempts to disparage the eidograph (fig. 12).¹¹⁴

Wallace probably knew by this time that the writer of that critical minority report had been Robert Stevenson. But in April 1831 he learnt that Stevenson, who had purchased one of the very first of Adie's re-engineered eidographs, had also provided the committee with what appears to have been an account of this eidograph's performance over the previous years – a situation potentially damaging to the

eidograph's reputation.¹¹⁵ The Society refused to surrender this account (this in any case was privately said to be 'amissing').¹¹⁶ Brewster was no longer closely involved in the running of the Society and able to give support, and so Wallace, claiming that the members had 'formed a combination to do me all the injury they can', resigned in a great huff.¹¹⁷

Dunn, however, retained the Society's confidence and served it loyally for many years. His pantograph was one of the instruments shown in the 1840 exhibition for the British Association meeting in Glasgow, so all three of the rival instruments were exhibited under one roof.¹¹⁸ By this time John Dunn, in conjunction with his brother Thomas, had expanded his business to Glasgow and was specifically advertising his pantograph for civil engineers, surveyors, engravers and lithographic draughtsmen as 'the most complete, delicate, and simple Instrument yet made, for Copying, Enlarging, or Reducing Drawings of every kind'.¹¹⁹ After John Dunn's death

in 1841, the partnership with his brother was technically bankrupt, but Thomas was able to recover the Edinburgh side of the business which he ran until the late 1860s. The pentograph continued to sell, and the highest serial number recorded so far is 866.¹²⁰

By contrast the eidograph has survived to recent times. Its main London outlet was probably through the business set up by Alexander Adie's youngest son Patrick in 1844: by about 1865 he was issuing an extensive wholesale catalogue of instruments which included the eidograph.¹²¹ Like several other similar firms, Patrick Adie ran a wholesale and retail business in which he sold specialist instruments of his own manufacture as well as material he bought in from

other specialists. It is quite likely that the 'Wallace's Eidographs' advertised in the catalogues of firms such as E. M. Clarke and L. Casella were supplied by Adie.¹²² The eidograph was given a boost in popularity by W. F. Stanley's writings, and his firm made further improvements to the instrument in about 1870.¹²³ It was still being offered by Stanley in 1931.¹²⁴

Wallace would have said that this long-lived success of the eidograph was no less than the instrument deserved. However, as the controversy surrounding the introduction of the various devices in this group demonstrates, a good idea is often not enough: the inventor's claim may only be as strong as his patron's influence.

NOTES AND REFERENCES

For permission to examine and quote original manuscripts I must thank the Trustees of the National Library of Scotland (NLS), the Royal Scottish Society of Arts (RSSA) and the Royal Society of Edinburgh. David Bryden first drew this episode to my attention and has encouraged me to pursue it. I am particularly grateful for the advice of Alison Morrison-Low, and I must acknowledge the help of the following: Dr Iain Brown, Patrick Cadell, Peter Delehar, Bill Hurt, Stephen Johnston, Ken Smith, and especially Patricia Walsh. The author is Honorary Archivist to the RSSA.

- 1 NLS, Department of Manuscripts, RSSA Archive, principally comprising Accession 4534 (formal communications to the Society) and Deposit 230 (minute books, etc.). The correspondence discussed here was located amongst miscellaneous papers in Dep. 230/68.
- 2 The judges and lawyers of Edinburgh's legal establishment were almost exclusively from landed families and were estate owners in their own right. Like many of Scotland's gentry and aristocracy they supported fashionable New Town residences, and perhaps houses near Edinburgh in addition to country seats if their estates were in more distant parts. It is not a surprise therefore to find that the law terms, as well as the university terms, played a part in regulating Edinburgh social life, with land owners often returning to their estates in the summer months.
- 3 The progress with this project is described in Andrew G. Fraser, *The Building of Old College* (Edinburgh 1989).
- 4 W. H. Makey, 'George Drummond's New Edinburgh', in A. H. B. Masson and A. D. C. Simpson (eds), *Edinburgh's Infirmary* (Edinburgh 1979), pp. 19-22.

- 5 Drummond's role in University appointments is discussed in J. B. Morrell, 'The Edinburgh Town Council and its University, 1717-1766', in R. G. W. Anderson and A. D. C. Simpson (eds), *The Early Years of the Edinburgh Medical School* (Edinburgh 1976), pp. 46-65.
- 6 The University was increasingly failing to adapt to changing circumstances. The control of the Professor of Anatomy over surgical teaching had already resulted in the imposition of Regius Surgery chairs. But the 1826 Royal Commission on the Scottish Universities failed to move the vested interests that prevented a proportion of extra-mural instruction becoming accepted for degrees; the University failed to provide increased levels of practical instruction in chemistry and anatomy so that courses would qualify for the new naval and military medical entrance requirements; and ultimately the University failed to respond to the threat posed by the new University of London by offering competing courses.
- 7 R. G. W. Anderson, *The Playfair Collection and the Teaching of Chemistry at the University of Edinburgh, 1713-1858* (Edinburgh 1978), p. 39.
- 8 Alexander Bower, *The Edinburgh Student's Guide* (Edinburgh 1822).
- 9 Isobel Rae, *Knox the Anatomist* (Edinburgh and London 1964), pp. 40-47.
- 10 Steven Shapin, 'Brewster and the Edinburgh Career in Science', in A. D. Morrison-Low and J. R. R. Christie (eds), *Martyr of Science: Sir David Brewster, 1781-1868* (Edinburgh 1984), p. 17.
- 11 *Memoir of Professor Wallace* (London 1844), pp. 4-5; this

- anonymous obituary subsequently appeared in *Monthly Notices of the Royal Astronomical Society*, 6 (1845), p. 31. A recent account of Wallace's work is M. Panteki, 'William Wallace and the Introduction of Continental Calculus to Britain: A Letter to George Peacock', *Historia Mathematica*, 14 (1987), pp. 119-132. The link between Robison and Wallace has been explored further in T. N. Clarke, A. D. Morrison-Low and A. D. C. Simpson, *Brass & Glass: Scientific Instrument Making Workshops in Scotland* (Edinburgh 1989), pp. 26-27.
- 12 Craig Mair, *A Star for Seamen: The Stevenson Family of Engineers* (London 1978), pp. 50, 56, 63.
- 13 Clarke, Morrison-Low and Simpson, *Brass & Glass* (note 11), pp. 30-32.
- 14 A brief history of the Society is Neil Campbell and R. Martin S. Smellie, *The Royal Society of Edinburgh, 1783-1983* (Edinburgh 1983).
- 15 For an indication of the range of these activities see Davis D. McElroy, *Scotland's Age of Improvement: a Survey of Eighteenth Century Literary Clubs and Societies* (Pullman, Washington 1969). A valuable study of the dynamics of technical education is Steven Shapin, "'Nibbling at the Teats of Science": Edinburgh and the Diffusion of Science in the 1830s', in Ian Inkster and Jack Morrell (eds), *Metropolis and Province: Science in British Culture, 1780-1850* (London 1983), pp. 151-178.
- 16 A. D. C. Simpson, 'Globe Production in Scotland in the period 1770-1830', *Der Globusfreund, Journal for the Study of Globes and related Instruments*, Nos 35-37, pp. 21-32. Entry on Robert Kirkwood in J. Denovan, *The New Picture of Edinburgh, being an Accurate Guide to the City & Environs* (Edinburgh 1806), p. 325. The link between Audubon and Lizars is described in John Chancellor, *Audubon, A Biography* (London 1978), pp. 125-134, 139-140.
- 17 For details about David Brewster (1781-1868) I have drawn heavily on the most recent compilation of Brewster studies: Morrison-Low and Christie, *Martyr of Science* (note 10).
- 18 W. H. Brock, 'Brewster as a Scientific Journalist', in *ibid.*, pp. 37-42.
- 19 A. D. Morrison-Low, 'Published Writings of Sir David Brewster: A Bibliography', in *ibid.*, pp. 107-136.
- 20 Clarke, Morrison-Low and Simpson, *Brass & Glass* (note 11), pp. 38-39.
- 21 A. D. Morrison-Low, 'Scientific Apparatus associated with Sir David Brewster: An Illustrated Catalogue of the Bicentenary Display', in Morrison-Low and Christie, *Martyr of Science* (note 10), pp. 83-84.
- 22 A. D. Morrison-Low, 'Brewster and Scientific Instruments', in *ibid.* (note 10), pp. 58-65. The derivation of the word kaleidoscope is from the Greek *kalos* (beautiful), *eidōs* (form), *skopein* (to look).
- 23 *Ibid.*, p. 61.
- 24 *Idem.*
- 25 J. B. Morrell, 'Brewster and the early British Association for the Advancement of Science', in *ibid.* (note 10), pp. 24-29.
- 26 J. Ruthven to Brewster, 16 January 1815, NLS Dep. 230/68(1). Brewster's general concerns for the support of invention are clearly expressed in his 'History of Mechanical Inventions and Processes in the Useful Arts', *Edinburgh Journal of Science*, 5 (1821), pp. 113-116. The *Journal* provided regular space for communications about inventions, and new Scottish patents were listed.
- 27 An extended study of Alexander Adie (1775-1858) and the family business is included in Clarke, Morrison-Low and Simpson, *Brass & Glass* (note 11), pp. 25-84: the sympiesometer is discussed on pp. 35-38. The derivation of the name sympiesometer, referring to the use of hydrogen gas over the hydrostatic fluid, is from the Greek *sympiesis* (a pressing together), *metron* (a measure).
- 28 On Leslie's capillary instruments see *ibid.*, pp. 32-34, and Anderson, *Playfair Collection* (note 7), pp. 86-90.
- 29 Thomas Jones of London was initially authorised to make and sell the instrument: 'Observations by the Patentee', *Repertory of Arts, Manufactures and Agriculture*, 2nd series, 35 (1819), p. 265.
- 30 David Brewster, *op. cit.* (note 26). In this article Brewster also advocated 'some modification of the Board of Manufactures and Fisheries, by which that valuable institution may be made to embrace a wider and more useful range'.
- 31 Brewster's printed prospectus of June 1821 refers to the Society having been first proposed in public in December 1819 under the name of the 'Society for the Promotion of the Mechanical and Useful Arts in Scotland, for rewarding Inventions of Public Utility, and disseminating Useful Knowledge among the industrious classes of Society' (also recorded in the January 1820 issue of the *Edinburgh Philosophical Journal*, p. 193).
- 32 'Scientific Intelligence ... 39. School of Arts', *Edinburgh Philosophical Journal*, 5 (1821), p. 234: 'A School of Arts has been established in Edinburgh, for the instruction of mechanics in such branches of science as are of practical application in their several trades'.
- 33 Shapin, *op. cit.* (note 10), p. 20.
- 34 For a brief discussion of the Astronomical Institution and the New Observatory see H. A. Brück, *The Story of Astronomy in Edinburgh* (Edinburgh 1983), pp. 7-11.
- 35 For example, Maya Hambly, *Drawing Instruments, 1580-1980* (London 1988), pp. 130-131, following William Wallace, 'Account of the Invention of the Pantograph ...', *Transactions of the Royal Society of Edinburgh*, 13 (1836), pp. 420-427. Wallace provides a translation of the relevant part of Scheiner's *Pantographice sive Ars Nova Delineandi* (Rome 1631). The

- word pantograph is from the Greek *pan* (all), *graphein* (to write).
- 36 Summarised in Wallace, *op. cit.* (note 35), pp. 418-419.
- 37 *Ibid.*, p. 419.
- 38 Sample etchings of medallic heads were provided by Andrew Smith in May 1821: letter of Smith to Brewster, 11 May 1821, NLS Acc. 4534/3(1821). William Wallace provided similar samples: letter of Wallace to John Robison, 26 December 1822, NLS Acc. 4534/4(1822), and Wallace, *op. cit.* (note 35), pp. 430, 459, referring to the use of two instruments in series to effect substantial reductions.
- 39 The work of Peter Hill (1778-fl.1845) is discussed in Clarke, Morrison-Low and Simpson, *Brass & Glass* (note 11), pp. 11-14, and the pantograph is described on p.15. It is in the collection of the National Museums of Scotland (NMS). Inv. T1980.177 (Arthur Frank Collection).
- 40 Edward H. Pinto and Eva R. Pinto, *Tunbridge and Scottish Souvenir Woodware* (London 1970), discuss the Smith business in pp. 90-119, based principally on the earlier research of Lord David Stuart. The brothers William Smith (1795-1847) and Andrew Smith (1797-1869) were in business as W. & A. Smith from at least 1823 until the dissolution of the partnership in 1843, but the joint name was revived by Andrew with his son William in 1847. Trading in Birmingham continued until 1904. Their principal early products were snuff boxes and razor strops (for which they held a Royal Warrant). The pantograph affair seems to have been unknown to Stuart or the Pintos and it fills a gap in their treatment of Andrew's establishment in business.
- 41 Letter of James Boaz, Secretary, [to Andrew Smith] in printed advertisement and testimonials sent to Brewster on 15 January 1823, NLS Acc. 4534/5(1823).
- 42 James Cleland was Glasgow Superintendent of Public Works, and in 1821 conducted the Government enumeration of the inhabitants of Glasgow; he contributed the article on 'Glasgow' for Brewster's *Edinburgh Encyclopaedia*: for Cleland see W. Anderson, *The Scottish Nation*, 3 vols (Edinburgh 1875), I, pp. 649-651. In his 1821 prospectus for the Society, Brewster announced corresponding committees for Glasgow, Aberdeen, Perth and Inverness.
- 43 Writing on 19 May 1821. Andrew Smith asked Brewster to pass his respects to several of Brewster's 'friends', notably Sir George Mackenzie and David Bridges (who provided Smith with an introduction to the Wernerian Society): NLS Acc. 4534/3(1821).
- 44 M. M. Gordon, *The Home Life of Sir David Brewster* (Edinburgh 1869), p. 215.
- 45 The derivation of the word apograph is from the Greek *apo* (from), *graphein* (to write), hence *apograph* (a copy). The name had certainly been coined by 20 April when Brewster and Mackenzie gave their public support for the device. Although the layout of the instrument appeared novel, a later account (which can be attributed to Wallace) suggested an association with a very simple (and well known) device used by artists who specialised in drawing portrait silhouettes: 'Pantograph'. *Supplement to the Fourth, Fifth and Sixth Editions of the Encyclopaedia Britannica*, 6 vols (Edinburgh 1824), VI, p. 109.
- 46 The description was to be based on the instrument provided for Brewster on 19 May 1821. Smith was anxiously ordering copies of the 'Philosophical journal' from Brewster on 11 June and expecting to hear from him about the published description 'almost immediately': NLS Dep. 230/68(1). Four months later he was expressing surprise 'that there is no notice taken of my instrument in your journal': Smith to Brewster, 16 October 1821, NLS Dep. 230/68(1).
- 47 The proposal was apparently made by Brewster in a letter of 30 April 1821, and an apograph with specimens of its work were sent on 19 May for Brewster to show to the Board: Smith to Brewster, 19 May 1821, NLS Acc. 4534/3(1821).
- 48 Brewster's 'Certificate' of commendation, dated 20 April 1821, is reproduced in manuscript by Smith in literature supplied to the Earl Spencer (papers with NMS T1976.66), and in the printed testimonials sent to Brewster on 15 January 1823: NLS Acc. 4534/5(1823). The demonstration of the apograph is recorded in the manuscript minutes of the Society (information from the late Jessie Sweet), but not in the printed account: the fact that the latter was edited by Jameson is probably significant (see below, note 50).
- 49 Smith wrote on 19 May 1821 to enquire whether several orders, including Stevenson's, were to be constructed in brass at £5.50 or mahogany at £3.10.0. By October 1821 George Bartholomew had an improved form of apograph which could make two copies at once, and Smith asked him to demonstrate it to Brewster: Smith to Brewster, 16 October 1821, NLS Dep. 230/68(1).
- 50 Brock, *op. cit.* (note 18), pp. 38-39.
- 51 Smith to Brewster, 11 June 1821, NLS Dep. 230/68(1). The order from the Board of Ordnance was placed in late July 1821 on the authority of General Gother Mann, Inspector-General of Fortifications: R. H. Crowe to William Smith, 27 July 1821, reproduced in printed testimonials, NLS Acc. 4534/5(1823). Smith styled himself 'Apograph maker to the Board of Ordnance' in his letter to Brewster of 13 September 1821: NLS Acc. 4534/3(1821).
- 52 Bate's terms were as follows: 'Mr Bate ... strongly recommends taking out a patent for England and for this purpose he will agree to advance £100 on the following terms - viz The Patent to lie in his hands as security for the money laid out. That he shall be allowed to manufacture the whole of the Instr[ument] charging the *neat expence* of workmanship and materials. And to have 25 p[er] C[en]t upon

- the Same for his outlay and trouble till once we are enabled to pay him the cash with 15 pr Ct for all that he Sells – And should the profits never pay the Patent Mr. B has still the same claim on us for his money': Smith to Brewster, 23 June 1821, NLS Dep. 230/68(1).
- 53 Smith's letter to Brewster of 24 July 1821, with a postscript by William McCormick, Editor of the *Ayr Advertiser*, explained that this had been prepared after the commendations from Brewster and the Glasgow Philosophical Society had been received: NLS Dep. 230/68(1). The paper's interest had been signalled to Brewster six weeks earlier: letter of 11 June 1821, NLS Dep. 230/68(1). The publication triggered others in the *Gentleman's Magazine* of July 1821 and in the *Edinburgh Magazine and Literary Miscellany* of October 1821.
- 54 The public correspondence of the dispute is published in Thomas Reid, *An Account of the Apograph by Thomas Reid: with part of the Evidence upon which he claims a Right to the Invention of that Instrument; being an Answer to the Aspersions of Mr Andrew Smith of Mauchline, the Pretended Inventor of the Apograph* (Ayr 1822). This was published at the Ayr Courier Office, and Brewster was sent a copy by Reid's brother James on 31 January 1822: NLS Dep. 230/68(1). The *Ayr Advertiser* description of 19 July 1821 is reproduced on p. 2, and Thomas Reid's reply of 24 July 1821 on p. 3. Reid felt compelled to publish this account because the Editor of the *Ayr Advertiser* struck out portions of his letters, and required him to pay for the publication of what remained as if they were advertisements.
- 55 Smith to Brewster, 13 September 1821, NLS Acc. 4534/3(1821).
- 56 Thomas Reid claimed to have invented the apograph in December 1820 to facilitate making a reduced copy of a map for the minister at Tarbolton: Reid, *Account of the Apograph* (note 54), p.1. The Rev. John Campbell's confirmation of this was sent to Brewster in January 1822: Campbell to Reid, 17 January 1822, NLS Dep. 230/68(1). Significantly, Reid claimed that the idea was developed from the horizontal form of the 'profile machine' (see above, note 45).
- 57 Reid to the Editor of the *Ayr Advertiser*, 10 August 1821, in *ibid.*, pp. 6-8.
- 58 *Ibid.*, p.18.
- 59 Smith to the Editor of the *Ayr Advertiser*, 22 August 1821, in *ibid.*, pp. 8-9.
- 60 *Ibid.*, p.12.
- 61 James Reid to Brewster, 31 January 1822, and Smith to Brewster, 21 February 1822: NLS Dep. 230/68(1).
- 62 Smith to Brewster, 13 September 1821, NLS Acc. 4534/3(1821).
- 63 Wallace to Brewster, 29 November 1821, NLS Acc. 4534/3(1821).
- 64 Anon., *Memoir of Professor Wallace* (London 1844), pp. 6-8.
- 65 *Ibid.*, p. 9.
- 66 Smith to Brewster, c. 23 April 1821, NLS Dep. 230/68(1).
- 67 Wallace to John Robison, Secretary, 26 December 1822, NLS Acc. 4534/4(1822).
- 68 Wallace, *op. cit.* (note 35), pp. 427-428.
- 69 A fusee chain is a very fine chain used in a watch to link the movement through a tapering fusee barrel to the driving spring in such a way as to transmit a uniform torque as the spring unwinds. The derivation of the name eidograph is from the Greek *eidos* (form), *graphein* (to write).
- 70 Wallace to Brewster, 24 November 1821, NLS Acc. 4534/3(1821). Glenlee was the title taken by Sir William Miller (1755-1846) when he was appointed to the Court of Session in 1795.
- 71 Smith to Brewster, 19 May 1821, NLS Acc. 4534/3(1821).
- 72 Wallace to Brewster, 24 November 1821, NLS Acc. 4534/3(1821).
- 73 Reid, *Account of the Apograph* (note 54), pp. 10-11.
- 74 Royal Society of Edinburgh, MS. Minutes of Meetings of the Physical and Literary Classes, 1793-1824.
- 75 Wallace to Brewster, 24 November 1821, NLS Acc. 4534/3(1821).
- 76 Wallace's formal submission of 26 December 1822 to the Society of Arts only referred to 'the Artist, who has engaged to construct it': NLS Acc. 4534/4(1822). Bate is named in the account in the *Encyclopaedia Britannica's Supplement, op. cit.* (note 45), and in the version reprinted in the *Glasgow Mechanics Magazine*, 17 April 1824. It is not known when the commission was given to Bate, but it was almost certainly at the instigation of Brewster and was probably linked to advice given to Andrew Smith against pursuing his projected patent arrangement with Bate.
- 77 Wallace to John Robison, Secretary, 26 December 1822, NLS Acc. 4534/4(1822). The voyage lasted for about four years and the numerous charts produced (published by the Hydrographic Office in 1828) became the standard survey. The voyage is described in Owen's *Narrative of Voyages to explore the Shores of Africa, Arabia and Madagascar* (London 1833).
- 78 Wallace to Robison, 26 December 1822, NLS Acc. 4534/4(1822).
- 79 Wilson Lowry (1762-1824) was one of the most prominent engravers of his day and was perhaps the best qualified to appreciate the merits of Wallace's two instruments. He himself had invented several ingenious drawing and engraving instruments. He had been engaged for over 20 years with the plates for Abraham Rees' *The New Cyclopaedia, or Universal Dictionary of Arts and Sciences*, published in parts between 1802 and 1820: the plates alone occupied six volumes. Lowry's death in 1824 prevented his assessment of Wallace's reversing

- instrument. An interest in the conventional eidograph was shown by his son, J. Wilson Lowry, who was apparently the author of the note 'Description of an Improved Pantograph for Copying Drawings' in Alexander Tilloch's *The Mechanic's Oracle and Artisan's Laboratory & Workshop* for 1825: this is illustrated in an 1824 plate by J. W. Lowry, but is merely signed 'Delineator' (I am grateful to David Bryden for drawing this article to my attention). This pantograph is similar in layout to the device later produced in Edinburgh by John Dunn, and may perhaps have influenced his thinking.
- 80 Smith to Brewster, 15 January 1823, NLS Acc. 4534/5(1823).
- 81 Martin to Smith, 11 September 1822, reproduced in printed testimonials, NLS Acc. 4534/5(1823).
- 82 Smith to Brewster, 15 January 1823, NLS Acc. 4534/5(1823). Charles Muss (1779-1824) was one of the principal artists in Collins' glass-works near Temple Bar, London, and was noted for his copies on glass of old masters. He was appointed enamel-painter to George III and George IV. His early death in 1824 deprived Smith of a valuable advocate. His testimonial of 9 September 1822 is reproduced in NLS Acc. 4534/5(1823).
- 83 Smith to Brewster, 15 January 1823, NLS Acc. 4534/5(1823).
- 84 'It is now about three months since I came to London, partly upon my old business of selling the work of Ayr though at present really for the purpose of having my Instruments finished in a proper stile ... I now have my Instruments finished in the best and latest manner ...': Smith to Brewster, 15 January 1823, NLS Acc. 4534/5(1823).
- 85 Inv. NMS T1976.66, constructed in black-stained oak and brass, and acquired through the interest of Peter Delehar. Smith had earlier indicated that a more expensive version would be available in brass (see above, note 49). An instrument which may be an example of the brass version is in the Istituto Geografico Militare, Florence (kindly drawn to my attention by Peter Delehar and Alison Morrison-Low). Dr Anita McConnell has noted that Willich began as a Russia merchant, moved around the city, ran the 'Lithographic Press' from Picket Street, and moved on to other things in the space of a few years.
- 86 *The Edinburgh Geographical and Historical Atlas* (Edinburgh [1831]), also titled the 'New Edinburgh General Atlas or a Complete Collection of Maps of the Empires, Kingdoms and States throughout the World: The Maps drawn & engraved by W. H. Lizars, Edinburgh'. Many of the maps are dated 1823.
- 87 John Lizars, *A System of Anatomical Plates of the Human Body: accompanied with Descriptions, and Physiological, Pathological & Surgical Observations*, 12 parts (Edinburgh [1823-26]). W. H. Lizars also illustrated his brother's *System of Practical Surgery, with Numerous Explanatory Plates, the Drawings after Nature* (Edinburgh 1838-39).
- 88 The first General Meeting was held on 18 November 1822. The eidograph having been formally proposed for consideration on 26 December, it was amongst the items considered by the Mechanical Arts Committee on 27 December, and then again in committee on 31 December, 7 and 14 January 1823: these are recorded in Brewster's first 'Proceedings of the Society of Arts for Scotland', *Edinburgh Philosophical Journal*, 9 (1823) p. 190, but none are included in the MS. 'Minute Book of the Society of Arts for Scotland No. 1', 1822-30: NLS Dep. 230/1.
- 89 Single MS. sheet, identified as a minute of the General Meeting of 17 March 1823, but in fact of one of the earlier committee meetings, perhaps of 31 December: inserted in MS. 'Minute Book ... No. 1', NLS Dep. 230/1. Wallace noted in his submission letter of 26 December 1822 that Lizars was also on the [Mechanical Arts] Committee, but he is not listed by Brewster in *ibid.*, p. 189: NLS Acc. 4534/4(1822).
- 90 Brewster, *ibid.*, p. 190.
- 91 Papers of the Board of Trustees for Fisheries, Manufactures and Improvements in Scotland have been checked at the Scottish Record Office: SRO NG.1.
- 92 The Council's recommendation was made on 7 December 1825 (when Wallace was also proposed as Secretary of the Mechanical Department) and the medal was awarded on 26 May 1827: 'Minute Book ... No. 1', NLS Dep. 230/1.
- 93 *Catalogue of the Exhibition of Models and Manufactures, &c. at the Tenth Meeting of the British Association for the Advancement of Science* (Glasgow 1840), p. 20.
- 94 Papers with instrument No. 156 at the Science Museum, London, Inv. 1980-1162, previously in the Wellcome Institute's historical collection.
- 95 Number 143 (private collection) and an unnumbered instrument (NMS Inv. T1984.172) were sold by Mason of Dublin; No. 156 (Science Museum Inv. 1980-1162) was sold by Dollond, and No. 368 (NMS Inv. T1982.119) by William Harris, both of London; No. 422 (NMS Inv. T1978.91) was sold by Abraham & Lord of Liverpool.
- 96 NMS, Inv. T1967.140.
- 97 Whipple Museum of the History of Science, Cambridge, Inv. 1898.
- 98 *Supplement, op. cit.* (note 45), pp. 109-110: this occurs in the first part of the volume, issued in April 1823.
- 99 Information from Dr Anita McConnell, who is conducting a detailed study of Robert Brettell Bate.
- 100 On John Adie (1805-1857) see Clarke, Morrison-Low and Simpson, *Brass & Glass* (note 11), pp. 41-49.
- 101 NLS MS. 19973, ff. 65, 67. I am grateful to Patrick Cadell for drawing this to my attention.
- 102 Milne was a founder with Brewster of the School of Arts and the Society of Arts, and was a member of the Society's initial Mechanical Arts Committee. On Milne's business see *The Mercantile Age*, 12 (1887), p. 354, and D. Bruce Peebles, 'Address by the President', *Transactions of the Royal Scottish*

- Society of Arts*, 11 (1887), pp. 391-393.
- 103 Meeting of 17 June 1829: 'Minute Book ... No. 1', NLS Dep. 230/1.
- 104 *Catalogue, op. cit.* (note 93), p. 18.
- 105 W. Wallace, *Geometrical Theorems and Analytic Formulae ...* (Edinburgh, London and Cambridge 1839), pp. 136, 153. The accompanying plate illustrates the instrument, inscribed 'ADIE & SON, EDINBURGH' and 'W WALLACE INV^T. 1839. CHOROGRAPH'.
- 106 An example signed by Gardner & Co. of Glasgow, but certainly by Adie, is in the National Museums of Scotland, Inv. 1985.L10. Eidographs by Elliott & Sons of London and Ash & Son of Birmingham have been recorded, but not examined: S. Moscovitz, *Historical Technology*, catalogues 107 (Fall 1973) and 116 (Spring 1978).
- 107 On John Dunn (c. 1791-1841) and his brother Thomas (c. 1803-1893), see Clarke, Morrison-Low and Simpson, *Brass & Glass* (note 11), pp. 88-95.
- 108 Dunn's paper is annotated as received on 17 December 1829 and was read on 20 January 1830: it is transcribed in the 'Roll [of Communications] Book 1', 1829-1839, pp. 9-12: NLS Dep. 230/19.
- 109 The geography master at the 'New Academy' (Edinburgh Academy) had used one in the Summer of 1828 to prepare outline maps for classroom use: 'Roll Book 1', p. 12: NLS Dep. 230/19.
- 110 The reporting committee was chaired by James Milne's son, John Milne. Postponements of their report were announced on 17 February, 3 and 17 March, and it was finally presented on 31 March 1830: 'Minute Book ... Volume 2^d', 1830-1838, NLS Dep. 230/3.
- 111 The Report is transcribed in 'Roll Book 1', pp. 12-14, NLS Dep. 230/19. It records the decision to seek Wallace's view after an initial meeting on 5 February. Wallace's remarks were circulated to committee members before a second meeting held on 12 March: an undated transcript is in 'Roll Book 1', pp. 25-61. This is annotated to indicate that it was read to the Society on 14 April 1830.
- 112 'Roll Book 1', pp. 13-14: NLS Dep. 230/19.
- 113 Wallace, *op. cit.* (note 35), p. 435. Wallace claimed that his purpose in publishing this account was to 'prevent an useful invention from being lost, by having it recorded' (*ibid.*, p. 428), but it seems clear that he was as much concerned that there should be an accessible description of the re-engineered version, without having to acknowledge the correction.
- 114 *Ibid.*, p. 429.
- 115 Wallace's request 'to be furnished with a letter from Mr Robert Stevenson to the Conv. of the Committee on the Eidograph & Improved Pantograph' was discussed by the Council on 27 April 1831, and the request was directed to Milne because Stevenson's letter had been addressed to him '& never read in the Society': 'Minutes of Council [1]', 1822-1841: NLS Dep. 230/11. Stevenson's eidograph was passed down in the family engineering firm, and is now in private hands. It is engraved 'A Adie Edinburgh N^o 4' and is the only one of the original Adie version (with the fusee chain) known to me.
- 116 Council meeting of 30 November 1831: 'Minutes of Council [1]', NLS Dep. 230/11.
- 117 Wallace to James Tod, Secretary, 27 April 1831, NLS Acc. 4534/2/8. He repeated his demand for the return of Stevenson's note in a further letter to Tod of 15 November 1831: NLS Acc. 4534/2/9.
- 118 *Catalogue, op. cit.* (note 93), p. 17.
- 119 *Ibid.*, tailpiece advertisement, in which the instrument is referred to as his 'Improved Pantograph'.
- 120 In a private collection.
- 121 *Abridged Catalogue of Mathematical Instruments, &c. Manufactured by Adie, 395, Strand, (WC) London* (London n.d.).
- 122 E. M. Clarke, *Catalogue of Philosophical Apparatus* (London [c. 1845]), p. 16; L. Casella, *An Illustrated and Descriptive Catalogue of ... Instruments* (London 1871), p. 75.
- 123 W. F. Stanley, *Drawing Instruments*, 5th edn (London 1878), pp. 126-128.
- 124 W. F. Stanley & Co., *Catalogue*, 32nd edn (London 1931), p. 215.